

# SERVICE MANUAL

## **MST SERIES RUBBER CRAWLER CARRIER**

MACHINE MODEL	SERIAL No.
MST 500	50101 and up
MST 600	1601 and up
MST 700	70101 and up
MST 800	866 and up
MST 1100	M02107 and up
MST 1100	K11101 and up
MST 1500	15001 and up
MST 2000	M02107 and up
MST 2000	K20101 and up
MST 2200	22001 and up
MST 2500	25101 and up

**MOROOKA**

## INTRODUCTION

To allow the machine to maintain its performance over a long period, and to prevent breakdowns or trouble before they occur, it is important to carry out suitable operation, maintenance and inspection, troubleshooting, and repair work.

This service manual gives details of the **GENERAL, STRUCTURE AND FUNCTION, TESTING AND ADJUSTING, AND TROUBLESHOOTING** for the machine that are needed to carry out this work, in particular, inspection, troubleshooting, and repair work. For details of the engine, see the shop manual for engine.

This service manual has been prepared to help you to improve the quality of your repairs by giving correct knowledge of the product and correct methods of repair, and by enabling you to carry out correct judgment.

Please read the contents thoroughly and make good use of them in your work.

We are constantly trying to improve the contents of our service manuals, so if you have any opinions or suggestions about the manual, please do not hesitate to contact us.

---

# 01 GENERAL

---

General view .....	01- 2
Assembly drawing .....	01- 4
Dimension table .....	01- 5
Specifications .....	01- 6
Table of lubricant and water .....	01-12

# GENERAL VIEW

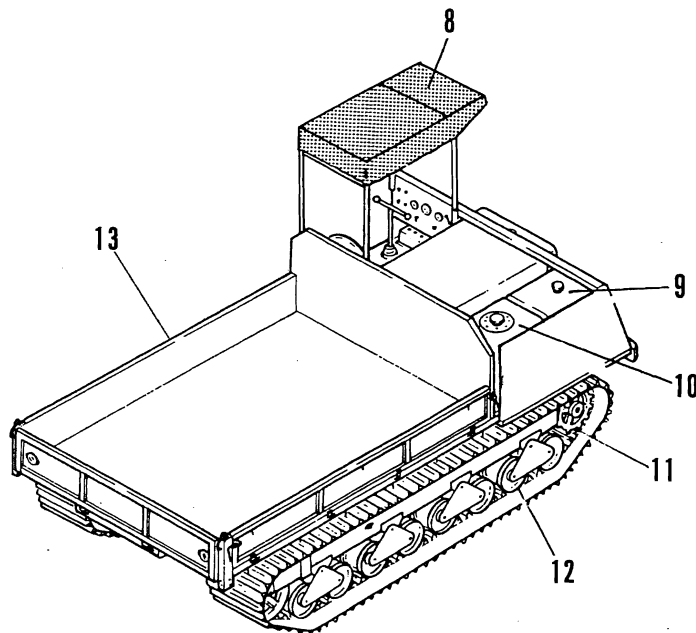
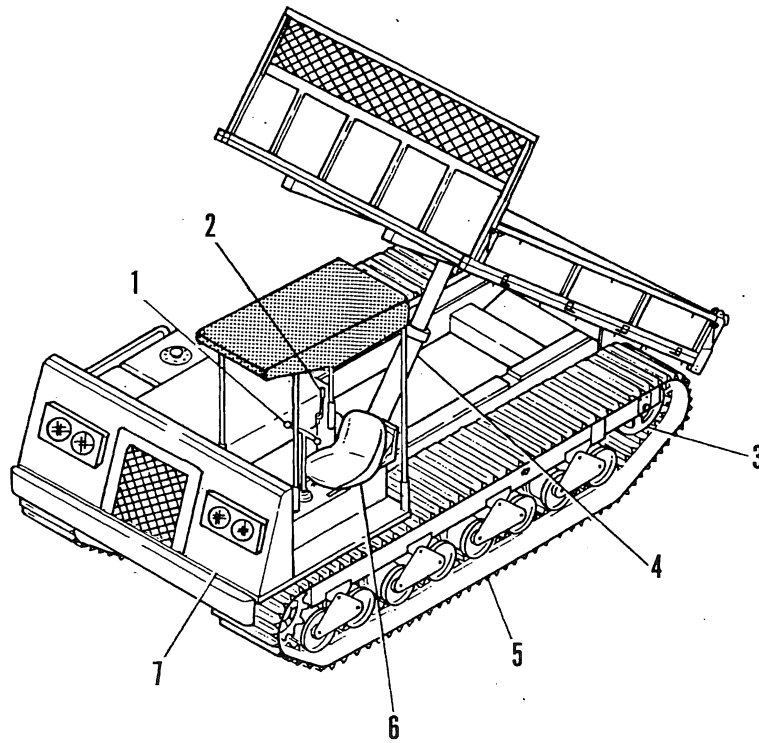

- 1. Travel control lever
- 2. Dump control lever
- 3. Rear idler
- 4. Dump cylinder
- 5. Rubber crawler

- 6. Operator's seat
- 7. Head lamp
- 8. Hood
- 9. Fuel tank
- 10. Hydraulic oil tank

- 11. Drive sprocket
- 12. Track roller
- 13. Carrier



# ASSEMBLY DRAWING

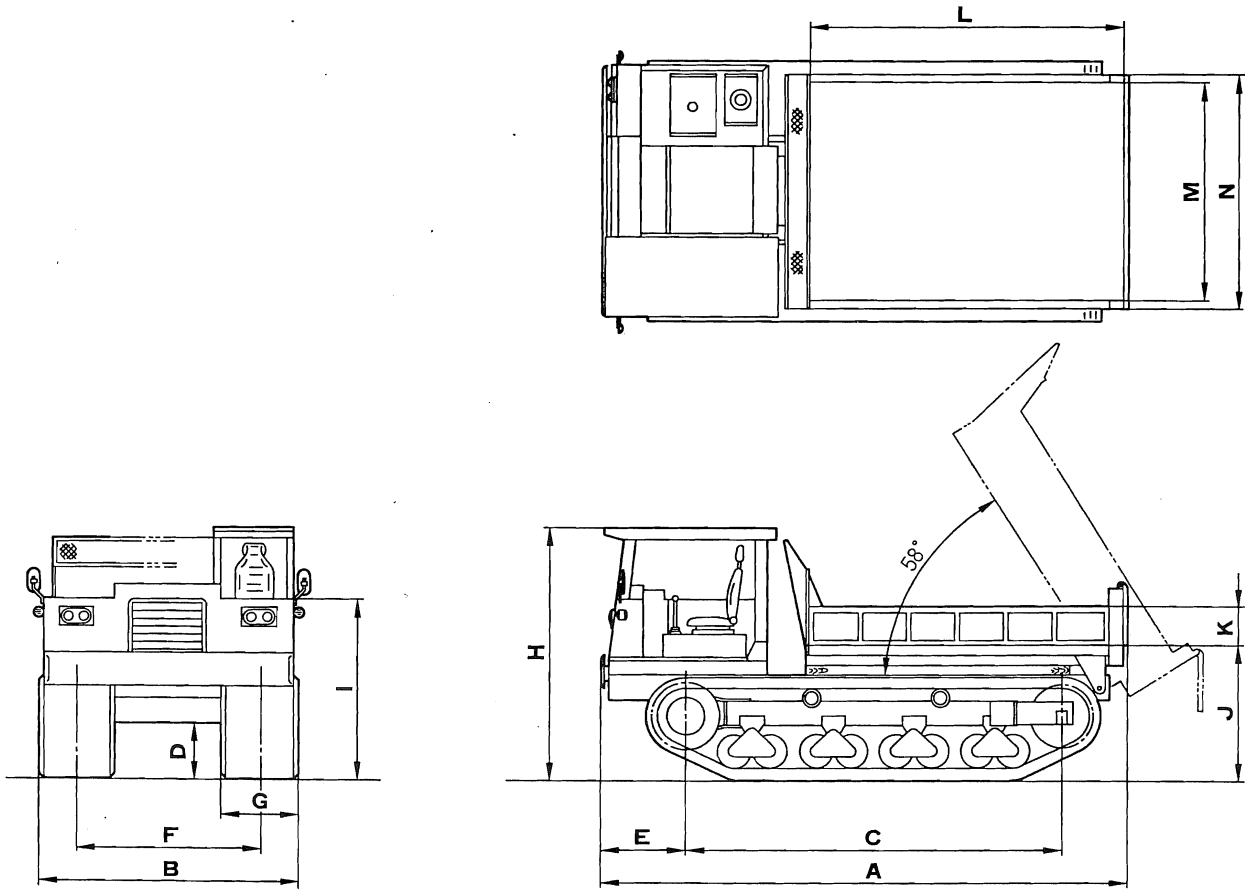

# DIMENSION TABLE

MODEL	MST-500	MST-600		MST-700	MST-800	
Serial No.	50101 and up	1601-2700	2701 and up	70101 and up	866-2500	2501 and up
A	3,600	3,840	3,830	4,200	4,500	4,365
B	1,850	2,000	2,000	2,150	2,300	2,300
C	2,450	2,930	2,930	2,930	3,160	3,130
D	350	355	355	355	440	470
E	500	500	500	500	580	636
F	1,400	1,500	1,500	1,600	1,700	1,700
G	450	500	500	550	600	600
H	2,150	2,200	2,200	2,250	2,300	2,343
I	1,400	1,425	-	1,500	1,550	-
J	900	940	940	1,028	1,140	1,160
K	350	350	350	350	350	350
L	2,150	2,250	2,250	2,550	2,600	2,600
M	1,650	1,700	1,700	1,850	2,000	1,950
N	1,800	1,880	-	1,950	2,100	-

MODEL	MST-1100	MST-1500	MST-2000	MST-2200	MST-2500	
Serial No.	11101 and up	15001 and up	20101 and up	22001 and up	25101 and up	
A	4,875	5,245	5,430	5,850	6,500	
B	2,400	2,500	2,700	2,750	3,000	
C	3,160	3,952	4,136	3,840	4,650	
D	440	530	540	500	600	
E	600	490	840	930	900	
F	1,700	1,800	1,900	2,000	2,100	
G	700	700	800	750	900	
H	2,300	2,440	2,500	2,600	2,700	
I	1,550	1,760	1,800	-	2,000	
J	1,140	1,280	1,350	1,385	1,550	
K	350	350	400	400	450	
L	2,850	3,100	3,400	3,600	4,000	
M	2,100	2,200	2,250	2,450	2,450	
N	2,200	2,300	2,400	-	2,650	

# SPECIFICATIONS

Model		MST-500	MST-600		MST-700
Serial No.		50101 and up	1601 – 2700	2701 and up	70101 and up
Machine weight (kg)		3,890	3,900	3,900	5,210
Performance	Max. loading capacity (kg)	2,500	3,000	3,000	3,500
	Dump body capacity (Struck) (m <sup>3</sup> )	1.2	1.4	1.4	1.5
	Min. turning radius (m)	1.9	2.0	2.0	2.2
	Grade ability (Deg)	35	35	35	35
	Travel speed (km/h)	0 – 11	0 – 12	0 – 12	0 – 10
Dimensions	Overall length (mm)	3,600	3,840	3,840	4,200
	Overall width (mm)	1,850	2,000	2,000	2,150
	Overall height (mm) (To the top of hood)	2,150	2,200	2,200	2,250
	Track gauge (mm)	1,400	1,500	1,500	1,600
	Track shoe width (mm)	450	500	500	550
	Number of links	65	78	78	76
	Link pitch (mm)	100	90	90	100
	Ground pressure (kg/cm <sup>2</sup> ) (Without load)	0.12	0.11	0.11	0.12
	Ground clearance (mm) (To the under surface of cross tube)	350	312	312	355
	Dump body width (mm)	1,600	1,700	1,700	1,850
	Dump body length (mm)	2,150	2,250	2,250	2,550
	Dump body height (mm)	350	350	350	350

MST-800		MST-1100	MST-1100	MST-1500	MST-2000
866 – 2400	2401 and up	M01101 and up	K11101 and up	15001 and up	M02101 and up
5,740	5,740	6,300	6,300	7,500	11,370
4,000	4,000	5,000	5,000	6,000	8,000
1.9	1.9	2.1	2.1	2.4	3.0
2.4	2.4	2.5	2.5	2.7	2.8
35	35	35	35	35	35
0 – 13	0 – 13	0 – 10	0 – 10	0 – 12	0 – 10
4,500	4,500	4,875	4,875	5,245	5,430
2,300	2,300	2,400	2,400	2,500	2,700
2,300	2,300	2,300	2,300	2,440	2,500
1,700	1,700	1,700	1,700	1,800	1,900
600	600	700	700	700	800
80	80	80	80	98	80
100	100	100	100	100	125
0.13	0.13	0.12	0.12	0.12	0.14
440	440	440	440	530	540
2,000	2,000	2,100	2,100	2,200	2,250
2,600	2,600	2,850	2,850	3,100	3,300
350	350	350	350	350	400

# SPECIFICATIONS

Model		MST-2000	MST-2200	MST-2500
Serial No.		K20101 and up	22001 and up	25101 and up
Machine weight (kg)		11,370	12,250	14,500
Performance	Max. loading capacity (kg)	8,000	10,000	10,000
	Dump body capacity (Struck) (m <sup>3</sup> )	3.0	3.52	4.4
	Min. turning radius (m)	2.8	3.23	3.4
	Grade ability (Deg)	35	35	35
	Travel speed (km/h)	0 – 10	0 – 14.5 (tow stage)	0 – 12 (two stage)
Dimensions	Overall length (mm)	5,430	5,850	6,500
	Overall width (mm)	2,700	2,928	3,000
	Overall height (mm) (To the top of hood)	2,500	2,600	2,700
	Track gauge (mm)	1,900	2,000	2,100
	Track shoe width (mm)	800	750	900
	Number of links	80	66	80 (Serial No. 25101–25106) 74 (Serial No. 25107 and up)
	Link pitch (mm)	125	150	150
	Ground pressure (kg/cm <sup>2</sup> ) (Without load)	0.14	0.17	0.15
	Ground clearance (mm) (To the under surface of cross tube)	540	500	600
	Dump body width (mm)	2,250	2,450	2,450
	Dump body length (mm)	3,300	3,600	4,000
	Dump body height (mm)	400	400	450

Model		MST-500	MST-600		MST-700
Serial No.		50101 and up	1601 – 2700	2701 and up	70101 and up
Engine	Engine model	KOMATSU 4D95L-1	mitsubishi 4D31	mitsubishi 4D31T	KOMATSU S4D95L-1
	Type	4-cycle, straight vertical, water cooling, direct injection type	4-cycle, straight vertical, water cooling, direct injection type	4-cycle, straight vertical, water cooling, direct injection type, turbocharged	4-cycle, straight vertical, water cooling, direct injection type, turbocharged
	No. of cylinders – bore x stroke (mm)	4 – 95 x 115	4 – 100 x 105	4 – 100 x 105	4 – 95 x 115
	Piston displacement (cc)	3,260	3,298	3,298	3,260
	Flywheel horsepower (HP/rpm)	77/2,800	74/2,800	87/2,800	87/2,500
	Max. torque (kgm/rpm)	22/1,600	21/1,600	28/2,200	29/1,600
	Fuel consumption ratio (g/PSh)	164	170	158	155
	Starting motor	24V, 2.8kW	24V, 3.2kW	24V, 3.2kW	24V, 2.8kW
	Alternator	24V, 15A	24V, 25A	24V, 25A	24V, 15A
Battery	12V, 70Ah x 2	12V, 100Ah x 2	12V, 100Ah x 2	12V, 100Ah x 2	
Power train	Type	HST	HST	HST	HST
	Main pump: Delivery (cc/rev)	43.0	51.6	51.6	51.6
	Max. hydraulic pressure (kg/cm <sup>2</sup> )	280	315	315	350
	Brake system	Service/parking	Service/parking	Service/parking	Service/parking
	Caution pressure of hydraulic charging (kg/cm <sup>2</sup> )	Max. 9.5	Max. 9.5	Max. 9.5	Max. 9.5
Work equipment hydraulic system	Charging pump: Delivery (cc/rev)	20.5	20.0	20.0	20.0
	Max. hydraulic pressure (kg/cm <sup>2</sup> )	175	175	165	175
	Dump control valve	Single-train spool	Single-train spool	Single-train spool	Single-train spool
	Dump cylinder	Double-acting, piston type x 1	Double-acting, piston type x 1	Double-acting, piston type x 1	Double-acting, piston type x 2
	Cylinder stroke	600	600	600	600
	Cylinder bore	90	90	90	90
	Piston rod O.D.	45	45	45	45

Model		MST-800		MST-1100	MST-1100
Serial No.		866 – 2400	2401 and up	M01101 and up	K11101 and up
Engine	Engine model	MITSUBISHI 4D31T	MITSUBISHI 4D34T	MITSUBISHI 6D14	KOMATSU S6D95L-1
	Type	4-cycle, straight vertical, water cooling, direct injection type, turbocharged	4-cycle, straight vertical, water cooling, direct injection type, turbocharged	4-cycle, straight vertical, water cooling, direct injection type	4-cycle, straight vertical, water cooling, direct injection type, turbocharged
	No. of cylinders – bore x stroke (mm)	4 – 100 x 105	4 – 104 x 115	6 – 110 x 115	6 – 95 x 115
	Piston displacement (cc)	3,298	3,907	6,557	4,890
	Flywheel horsepower (HP/rpm)	99/3,000	114/3,000	116/2,500	132/2,500
	Max. torque (kgm/rpm)	28/2,100	33/1,800	39/1,600	45/1,600
	Fuel consumption ratio (g/PSh)	160	162	170	155
	Starting motor	24V, 3.2kW	24V, 5.0kW	24V, 4.5kW	24V, 5.5kW
	Alternator	24V, 25A	24V, 30A	24V, 30A	24V, 15A
Battery	12V, 100Ah x 2	12V, 100Ah x 2	12V, 100Ah x 2	12V, 100Ah x 2	
Power train	Type	HST	HST	HST	HST
	Main pump: Delivery (cc/rev)	51.6	51.6	51.6	51.6
	Max. hydraulic pressure (kg/cm <sup>2</sup> )	350	350	385	385
	Brake system	Service/parking	Service/parking	Service/parking	Service/parking
	Caution pressure of hydraulic charging (kg/cm <sup>2</sup> )	Max. 9.5	Max. 9.5	Max. 9.5	Max. 9.5
Work equipment hydraulic system	Charging pump: Delivery (cc/rev)	20.0	20.0	20.0	20.0
	Max. hydraulic pressure (kg/cm <sup>2</sup> )	165	165	165	165
	Dump control valve	Single-train spool	Single-train spool	Single-train spool	Single-train spool
	Dump cylinder	Double-acting, piston type x 2	Double-acting, piston type x 2	Double-acting, piston type x 2	Double-acting, piston type x 2
	Cylinder stroke	600	600	710	710
	Cylinder bore	90	90	100	100
	Piston rod O.D.	45	45	60	60

MST-1500	MST-2000	MST-2000	MST-2200	MST-2500
15001 and up	M02101 and up	K20101 and up	22001 and up	25101 and up
MITSUBISHI 6D14T	MITSUBISHI 6D16T	KOMATSU SA6D110-1	CATERPILAR 3306DIT	MITSUBISHI 6D22T
4-cycle, straight vertical, water cooling, direct injection type, turbocharged	4-cycle, straight vertical, water cooling, direct injection type, turbocharged	4-cycle, straight vertical, water cooling, direct injection type, turbocharged	4-cycle, straight vertical, water cooling, direct injection type, turbocharged	4-cycle, straight vertical, water cooling, direct injection type, turbocharged
6 – 95 x 115	6 – 118 x 115	6 – 110 x 125	6 – 121 x 152	6 – 130 x 140
6,557	7,545	7,130	10,500	11,149
152/2,500	197/2,500	233/2,600	251/2,200	296/2,200
51/1,400	67/1,600	81,5/1,800	99/1,400	117/1,400
165	150	160	162	155
24V, 4.5kW	24V, 4.5kW	24V, 7.5kW	24V, 7.5kW	24V, 5.5kW
24V, 30A	24V, 30A	24V, 25A	24V, 35A	24V, 30A
12V, 120Ah x 2	12V, 120Ah x 2	12V, 120Ah x 2	12V, 120Ah x 2	12V, 120Ah x 2
HST	HST	HST	HST	HST
69.8	89.0	89.0	110.9	125.0
385	350 (Serial No. M02105 and up) 385 (Serial No. M02101–02104)	350 (Serial No. K20129 and up) 385 (Serial No. K20101–20128)	325	350
Service/parking	Service/parking	Service/parking	Service/parking	Service/parking
Max. 9.5	Max. 9.5	Max. 9.5	Max. 9.5	Max. 9.5
20.0	36.0	36.0	56.0	63.0 (Serial No. 25101–25106) 45.0 (Serial No. 25107 and up)
165	165	165	165	165
Single-train spool	Single-train spool	Single-train spool	Single-train spool	Single-train spool
Double-acting, piston type x 2	Double-acting, piston type x 2	Double-acting, piston type x 2	Double-acting, piston type x 2	Double-acting, piston type x 2
700	1,000	1,000	1,000	1,000
110	130	130	130	130
60	70	70	70	70



# TABLE OF LUBRICANT AND WATER

RESERVOIR	KIND OF FLUID	AMBIENT TEMPERATURE						CAPACITY (ℓ)	
		-4 -20	14 -10	32 0	50 10	68 20	86°F 30°C	Specified amount	Refill capacity
Engine oil pan	Engine oil	SAE 30						MST-500 : 9.0	7.5
		SAE 10W						MST-600 : 7.0	6.0
		SAE 10W-30						MST-700 : 9.0	7.5
		SAE 10W-30						MST-800 : 7.0	6.0
		SAE 10W-30						MST-1100: 12.5	10.5
		SAE 10W-30						MST-1500: 20.0	18.0
Hydraulic tank	Hydraulic oil	# 3 2						MST-2000: 24.0	22.0
		# 4 6						MST-2200: 27.0	25.0
		# 5 6						MST-2500: 31.0	27.0
		# 3 2						MST-500 : 53	50
		# 4 6						MST-600 : 53	50
		# 5 6						MST-700 : 63	60
Fuel tank	Diesel fuel	ASTM D 975 No.1						MST-800 : 73	70
		ASTM D 975 No.2						MST-1100: 73	70
		ASTM D 975 No.2						MST-1500: 74	70
		ASTM D 975 No.2						MST-2000: 74	70
		ASTM D 975 No.2						MST-2200: 120	110
		ASTM D 975 No.2						MST-2500: 120	110
Cooling system	Water	Add antifreeze						MST-500 : 60	-
		Add antifreeze						MST-600 : 60	
		Add antifreeze						MST-700 : 60	
		Add antifreeze						MST-800 : 80	
		Add antifreeze						MST-1100: 80	
		Add antifreeze						MST-1500: 120	
Add antifreeze						MST-2000: 145			
Add antifreeze						MST-2200: 170			
Add antifreeze						MST-2500: 210			

ASTM: American Society of Testing and Material

SAE: Society of Automotive Engineers

API: American Petroleum Institute

Specified capacity: Total amount of oil including oil for components and oil in piping.

Refill capacity: Amount of oil needed to refill system during normal inspection and maintenance.

**NOTE:**

- (1) When fuel sulphur content is less than 0.5%, change oil in the oil pan every periodic maintenance hours described in this manual.  
Change oil according to the following table if fuel sulphur content is above 0.5%.

Fuel sulphur content	Change interval of oil in engine oil pan
0.5 to 1.0%	1/2 of regular interval
Above 1.0%	1/4 of regular interval

- (2) When starting the engine in an atmospheric temperature of lower than 0°C, be sure to use engine oil of SAE10W, SAE10W-30 and SAE15W-40, even though an atmospheric temperature goes up to 10°C more or less in the day time.
- (3) Use API classification CD as engine oil and if API classification CC, reduce the engine oil change interval to half.

---

# 10 STRUCTURE AND FUNCTION

---

Hydraulic piping .....	10- 2
Hydraulic circuit diagram (MST-600, 700) ...	10- 3
Hydraulic circuit diagram (MST-500) .....	10- 4
Hydraulic circuit diagram (MST-800 — 1500) .....	10- 8
Hydraulic circuit diagram (MST-1500, 2000) .....	10-10
Hydraulic circuit diagram (MST-2200) .....	10-12
Hydraulic circuit diagram (MST-2500) .....	10-14
Hydraulic pump (MST-500) .....	10-16
Hydraulic pump (MST-600 — 1500) .....	10-17
Hydraulic pump (MST-1500, 2000) .....	10-18
Hydraulic pump (MST-2200) .....	10-24
Hydraulic pump (MST-2500) .....	10-25
Travel motor (MST-500) .....	10-26
Travel motor (MST-600) .....	10-27
Travel motor (MST-700 — 2000) .....	10-28
Travel motor (MST-2500) .....	10-32
Travel motor (MST-2200, 2500) .....	10-33
Travel motor speed changing circuit (MST-2200, 2500) .....	10-34
Electrical circuit diagram (MST-500, 700, 1100, 2000) .....	10-36
Electrical circuit diagram (MST-600, 800, 1500, 2500) .....	10-38
Electrical circuit diagram (MST-600, 800) .....	10-39
Electrical circuit diagram (MST-2200) .....	10-40

# HYDRAULIC PIPING

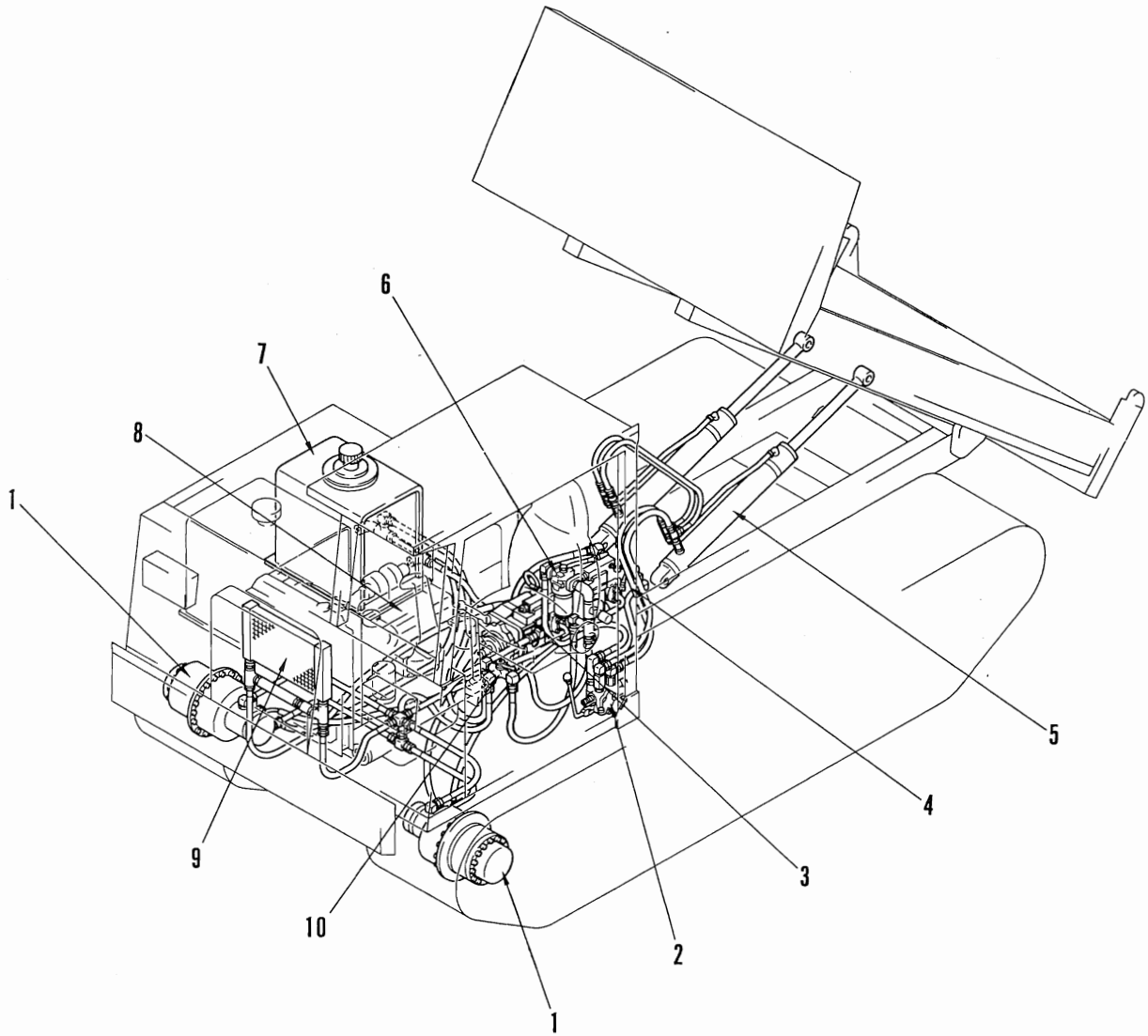

- |                       |                          |
|-----------------------|--------------------------|
| 1. Travel motor       | 6. Hydraulic line filter |
| 2. Dump control valve | 7. Hydraulic oil tank    |
| 3. Main pump          | 8. Engine                |
| 4. Charging pump      | 9. Oil cooler            |
| 5. Dump cylinder      | 10. Parking brake valve  |

## GENERAL

- The MST series adopt the HST (HydroStatic Transmission) by swash plate hydraulic pumps and motors. Therefore, they can withstand high-speed, high-pressure service conditions.

In particular not only sufficient strength is achieved against torsional vibration of the engine or sudden fluctuations in the engine load but also stable performance is obtained throughout the engine speed range.

In addition, the volumetric efficiency is so high that there is scarcely any oil leakage and the efficiency does not drop even if the oil temperature rises.

The original servo transmission mechanism which is adopted facilitates the forward/neutral/reverse lever operation.

In addition to above, the HST is of a maniblock type, which eliminates the piping of servo valves, relief valves, etc., so that it is easy to disassemble and reassemble.

Furthermore, the travel motor of the MST-2200 and MST-2500 has a high/low speed selector mechanism, so it is possible to select a speed to match the change in the load.

## OUTLINE OF HYDRAULIC CONSTITUTION

- There are basically 2 hydraulic circuits, i.e., the HST to generate traveling power and the work equipment circuit to control the dump body.

The HST has a pump charging circuit with 2 sets each of hydraulic variable pumps and hydraulic motors at the center of the circuit. The 2 sets of tandem hydraulic pumps are equipped with a charging pump in the rearmost section.

The power train is connected directly to the engine.

The 2 sets of hydraulic motors are equipped with a final reduction gear and a parking brake; they are mounted in the right and left front.

The work equipment circuit consists of a dump control valve and a dump cylinder.

The dump control valve is of a single-train spool system for all models.

A double-acting, piston-type dump cylinder is adopted. One set are used in the MST-500 and 600. Two sets are used in the MST-700, 800, 1100, 1500, 2000, 2200 and 2500.

In addition to the above hydraulic equipment, the MST-2200 and 2500 are also equipped with a high-low 2-speed travel motor which can be switched between high and low speed by a solenoid valve operated by a switch in the operator's compartment.

# HYDRAULIC CIRCUIT DIAGRAM (MST-500)

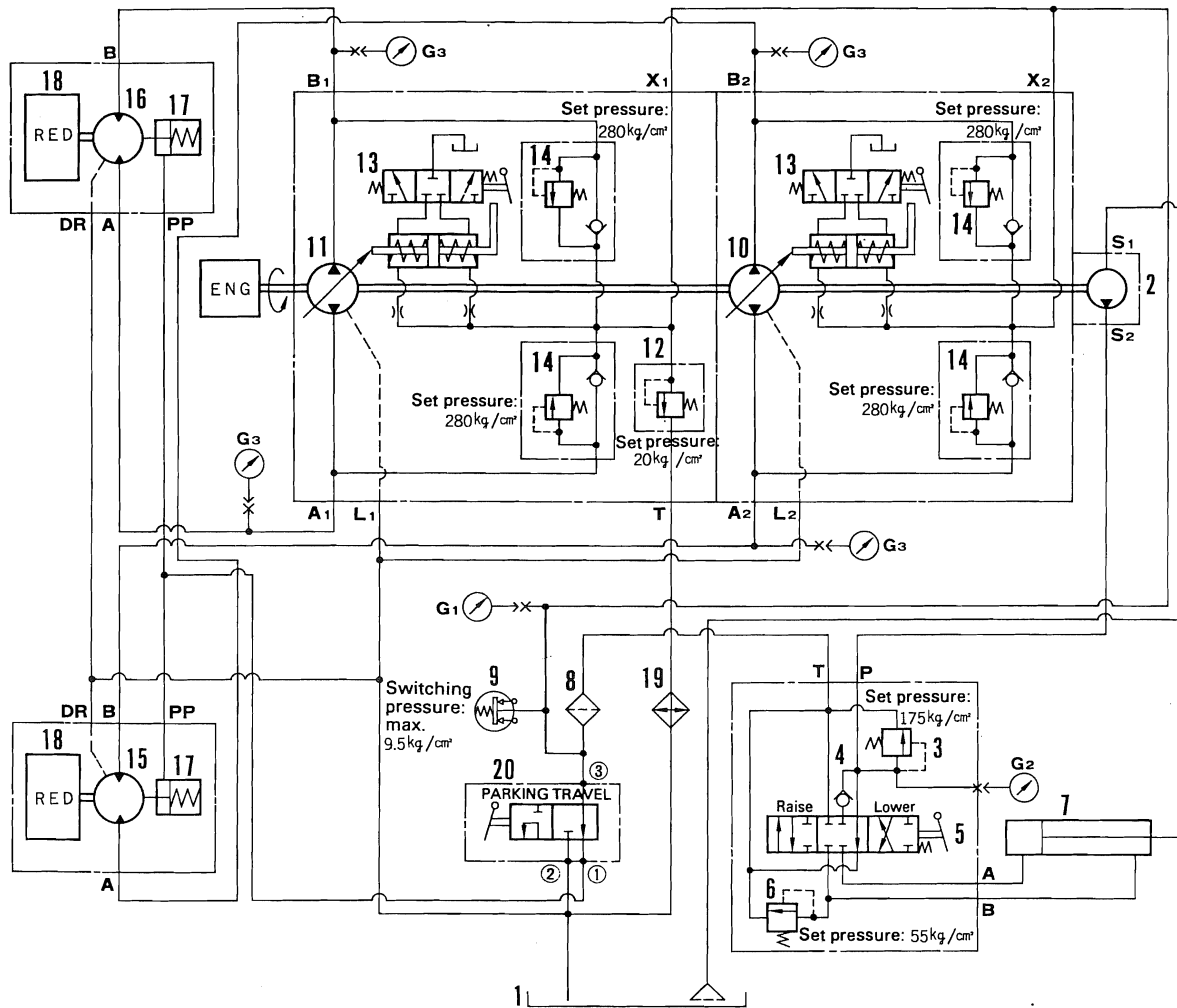

- |   |  |
|---|--|
| 1. Hydraulic oil tank                     | 13. Pump control valve                 |
| 2. Charging pump                          | 14. High-pressure relief valve         |
| 3. Main relief valve                      | 15. Travel motor (for left traveling)  |
| 4. Check valve                            | 16. Travel motor (for right traveling) |
| 5. Dump control valve                     | 17. Parking brake                      |
| 6. Over-load relief valve (Lower side)    | 18. Final drive                        |
| 7. Dump cylinder                          | 19. Oil cooler                         |
| 8. Hydraulic line filter                  | 20. Parking brake valve                |
| 9. Low-pressure switch                    |  |
| 10. Rear main pump (for left traveling)   |  |
| 11. Front main pump (for right traveling) |  |
| 12. Charging relief valve                 |  |
- 
- |  |
|--|
| G <sub>1</sub> . Plug for charging pressure of main pump       |
| G <sub>2</sub> . Plug for main relief pressure of dump circuit |
| G <sub>3</sub> . Plug for high-pressure of main pump           |

## OIL FLOW

- Oil in the hydraulic oil tank (1) is sucked up by charging pump (2) and enters port P of the control valve (5).  
If the control valve (5) is at the "HOLD" position, the oil which entered port P goes out of port T and flows completely to the HST circuit.  
If the control valve (5) is in an operating condition, it flows to the dump cylinder circuit.
- If the dump lever is at the "RAISE" or "LOWER" position, oil of the dump cylinder circuit opens the check valve (4), comes out of port A or B through the spool, enters bottom side or head side of the dump cylinder (7) and makes the dump body raise or lower. The oil which is returned to the cylinder is cleaned as it passes port T and the line filter (8) and flows to the HST circuit. The dump body raising pressure is set to 175 kg/cm<sup>2</sup> by the main relief valve (3).  
The dump body lowering circuit pressure is set to 55 kg/cm<sup>2</sup> by the over-load relief valve (6).
- If the control valve (5) is at the "HOLD" position, oil of the HST circuit flows completely through two circuits of the pump charging and parking brake release.
- The oil which flowed into the parking brake release circuit enters port ③ of the parking brake valve (20). If the parking brake lever is at the "TRAVEL" position, the oil which entered port ③ comes out of port ①, enters the brake port provided in the right and left travel motors and "releases" the parking brake (17).  
If the parking brake lever is at the "PARK" position, the port ③ and port ① of the parking brake valve close and the port ① and port ② open to return the oil at the brake ports in the motors to the hydraulic oil tank.
- The oil which flowed into the pump charging circuit enters port X<sub>2</sub> of the rear pump and then port X<sub>1</sub> of the front pump through the pump's piping and supplies the amount of oil required by the main pump.  
The hydraulic pressure in the charging circuit is set to 20 kg/cm<sup>2</sup> by the charge relief valve (12) built into the main pump.  
If the pump charging circuit pressure drops below 9.5 kg/cm<sup>2</sup>, the low-pressure switch (9) is activated to warn the operator by flashing the warning lamp in order to prevent pump seizure.
- The main pumps (10) and (11) change the swash plate angle by means of the pump control valve (13) interlocked with the travel lever to adjust forward, reverse, and discharge, and send oil to the traveling motors.  
A high-pressure relief valve (14) is built into the main pump to set the main pump's discharging pressure to 280 kg/cm<sup>2</sup>.
- The travel motors (15) and (16) turn according to the amount of oil sent from the main pump and their speed is reduced by the reduction gear (18) to drive the sprocket for running or turning the vehicle.

# HYDRAULIC CIRCUIT DIAGRAM (MST-600, 700)

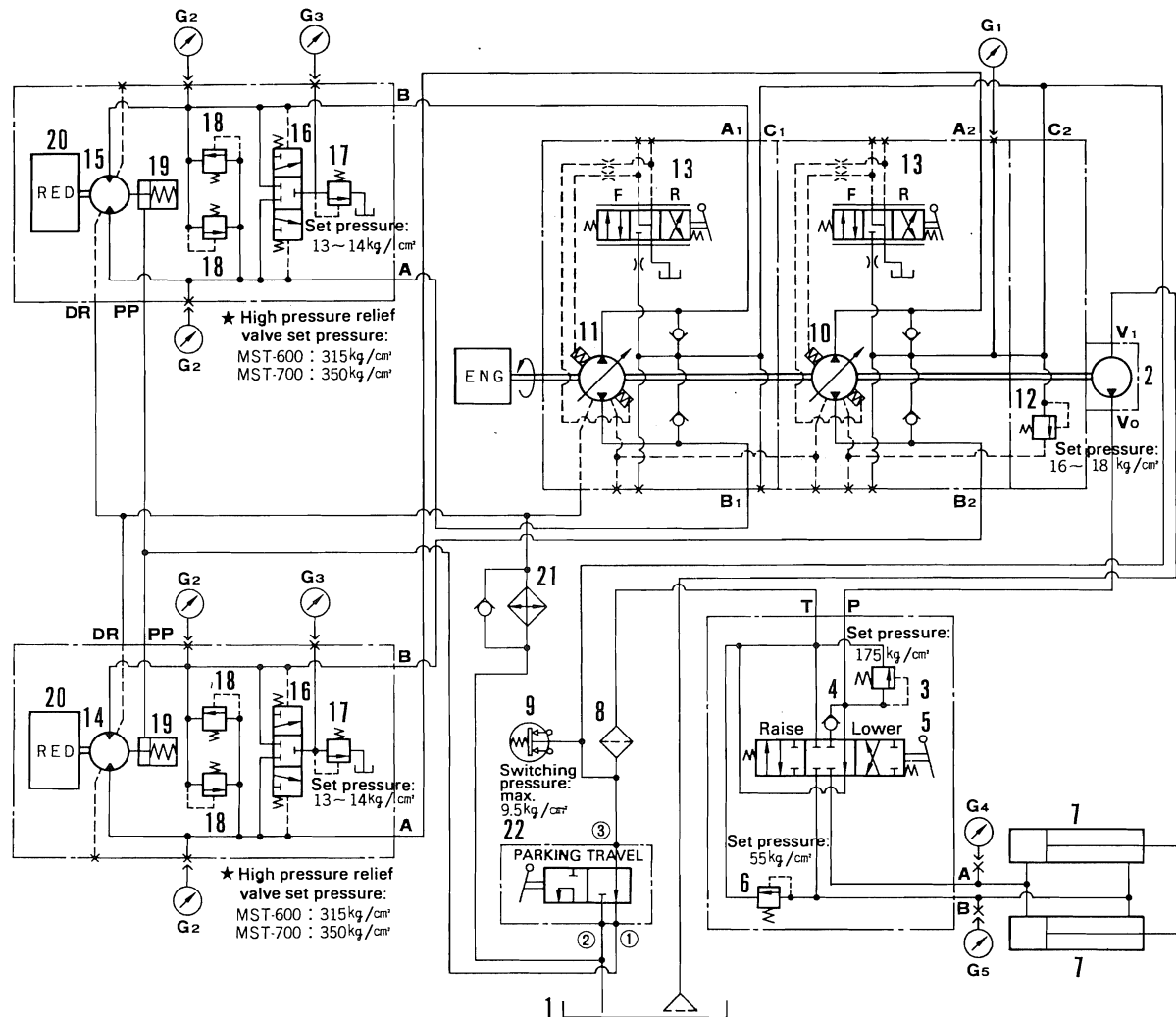

- |   |   |
|---|---|
| 1. Hydraulic oil tank                     | 14. Travel motor (for left traveling)                               |
| 2. Charging pump                          | 15. Travel motor (for right traveling)                              |
| 3. Main relief valve                      | 16. Shuttle valve   |
| 4. Check valve                            | 17. Motor charging relief valve                                     |
| 5. Dump control valve                     | 18. High-pressure relief valve                                      |
| 6. Over-load relief valve (Lower side)    | 19. Parking brake   |
| 7. Dump cylinder                          | 20. Final drive   |
| 8. Hydraulic line filter                  | 21. Oil cooler  |
| 9. Low-pressure switch                    | 22. Parking brake valve   |
| 10. Rear main pump (for left traveling)   | G <sub>1</sub> . Plug for charging pressure of main pump            |
| 11. Front main pump (for right traveling) | G <sub>2</sub> . Plug for high-pressure of main pump                |
| 12. Charging relief valve                 | G <sub>3</sub> . Plug for charging pressure of travel motor         |
| 13. Pump control valve                    | G <sub>4</sub> . Plug for main relief pressure of dump circuit      |
|   | G <sub>5</sub> . Plug for over-load relief pressure of dump circuit |

## OIL FLOW

- Oil in the hydraulic oil tank (1) is sucked up by charging pump (2) and enters port **P** of the control valve (5).

If the control valve (5) is at the "HOLD" position, the oil which entered port **P** goes out of port **T** and flows completely to the HST circuit.

If the control valve (5) is in an operating condition, it flows to the dump cylinder circuit.

- If the dump lever is at the "RAISE" or "LOWER" position, oil of the dump cylinder circuit opens the check valve (4), comes out of port **A** or **B** through the spool, enters bottom side or head side of the dump cylinder (7) and makes the dump body raise or lower. The oil which is returned to the cylinder is cleaned as it passes port **T** and the line filter (8) and flows to the HST circuit. The dump body raising pressure is set to 175 kg/cm<sup>2</sup> by the main relief valve (3). The dump body lowering circuit pressure is set to 55 kg/cm<sup>2</sup> by the over-load relief valve (6).
- If the control valve (5) is at the "HOLD" position, oil of the HST circuit flows completely through two circuits of the pump charging and parking brake release.
- The oil which flowed into the parking brake release circuit enters port ③ of the parking brake valve (22). If the parking brake lever is at the "TRAVEL" position, the oil which entered port ③ comes out of port ①, enters the brake port provided in the right and left travel motors and "releases" the parking brake (19).

If the parking brake lever is at the "PARK" position, the port ③ and port ① of the parking brake valve close and the port ① and port ② open to return the oil at the brake ports in the motors to the hydraulic oil tank.
- The oil which flowed into the pump charging circuit enters port **C**<sub>2</sub> of the rear pump and then port **C**<sub>1</sub> of the front pump through the pump's piping and supplies the amount of oil required by the main pump.

The hydraulic pressure in the charging circuit is set to 16 – 18 kg/cm<sup>2</sup> by the charge relief valve (12) built into the main pump.

If the pump charging circuit pressure drops below 9.5 kg/cm<sup>2</sup>, the low-pressure switch (9) is activated to warn the operator by flashing the warning lamp in order to prevent pump seizure.

- The main pumps (10) and (11) change the swash plate angle by means of the pump control valve (13) interlocked with the travel lever to adjust forward, reverse, and discharge, and send oil to the traveling motors.
- The travel motors (14) and (15) turn according to the amount of oil sent from the main pump and their speed is reduced by the reduction gear (20) to drive the sprocket for running or turning the vehicle. A high-pressure relief valve (18) is built into the travel motor to set the main pump's discharging pressure. In addition, a flushing valve (combination of a shuttle valve (16) and a charge relief valve (17)) is built into the MST-600, and 700. It relieves the oil of the circuit which became the travel motor's discharging side (low-pressure side) to the oil cooler (21) to prevent overheating and clean hydraulic oil of the HST circuit.



# HYDRAULIC CIRCUIT DIAGRAM (MST-800 — 1500)

MST-800 Serial No. 866 —  
 MST-1100 Serial No. M01101 —, K11101 —  
 MST-1500 Serial No. 15001 — 15093

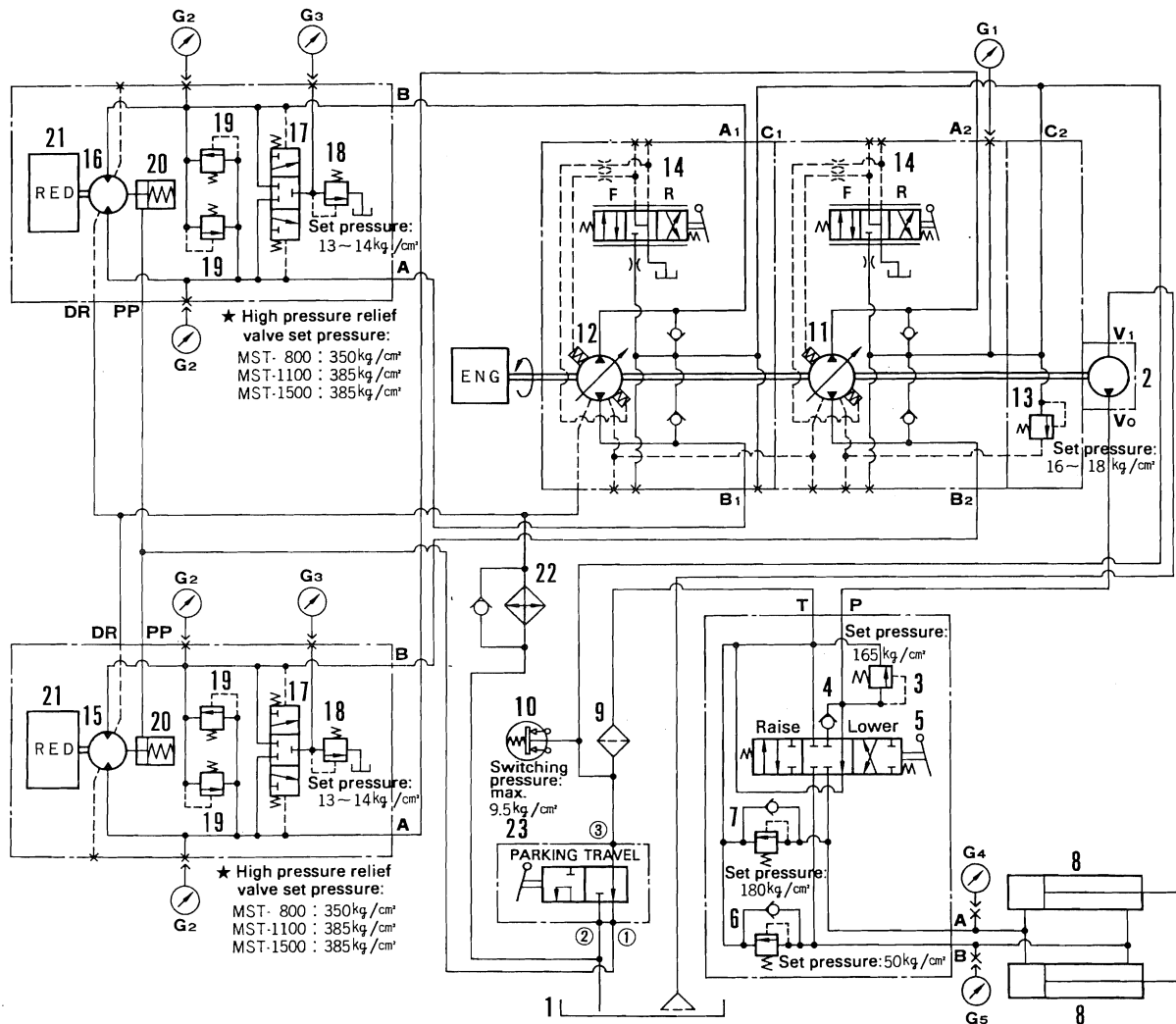

- |   |   |
|---|---|
| 1. Hydraulic oil tank                     | 15. Travel motor (for left traveling)                               |
| 2. Charging pump                          | 16. Travel motor (for right traveling)                              |
| 3. Main relief valve                      | 17. Shuttle valve   |
| 4. Check valve                            | 18. Motor charging relief valve                                     |
| 5. Dump control valve                     | 19. High-pressure relief valve                                      |
| 6. Over-load relief valve (Lower side)    | 20. Parking brake   |
| 7. Over-load relief valve (Raise side)    | 21. Final drive   |
| 8. Dump cylinder                          | 22. Oil cooler  |
| 9. Hydraulic line filter                  | 23. Parking brake valve   |
| 10. Low-pressure switch                   |   |
| 11. Rear main pump (for left traveling)   |   |
| 12. Front main pump (for right traveling) |   |
| 13. Charging relief valve                 |   |
| 14. Pump control valve                    |   |
|   | G <sub>1</sub> . Plug for charging pressure of main pump            |
|   | G <sub>2</sub> . Plug for high-pressure of main pump                |
|   | G <sub>3</sub> . Plug for charging pressure of travel motor         |
|   | G <sub>4</sub> . Plug for main relief pressure of dump circuit      |
|   | G <sub>5</sub> . Plug for over-load relief pressure of dump circuit |

## OIL FLOW

- Oil in the hydraulic oil tank (1) is sucked up by charging pump (2) and enters port **P** of the control valve (5).  
If the control valve (5) is at the "HOLD" position, the oil which entered port **P** goes out of port **T** and flows completely to the HST circuit.  
If the control valve (5) is in an operating condition, it flows to the dump cylinder circuit.
- If the dump lever is at the "RAISE" or "LOWER" position, oil of the dump cylinder circuit opens the check valve (4), comes out of port **A** or **B** through the spool, enters bottom side or head side of the dump cylinder (8) and makes the dump body raise or lower. The oil which is returned to the cylinder is cleaned as it passes port **T** and the line filter (9) and flows to the HST circuit. The dump body raising pressure is set to 165 kg/cm<sup>2</sup> by the main relief valve (3).  
The dump body lowering pressure is set to 50 kg/cm<sup>2</sup> by the over-load relief valve (6).
- If the control valve (5) is at the "HOLD" position, oil of the HST circuit flows completely through two circuits of the pump charging and parking brake release.
- The oil which flowed into the parking brake release circuit enters port ③ of the parking brake valve (23). If the parking brake lever is at the "TRAVEL" position, the oil which entered port ③ comes out of port ①, enters the brake port provided in the right and left travel motors and "releases" the parking brake (20).  
If the parking brake lever is at the "PARK" position, the port ③ and port ① of the parking brake valve close and the port ① and port ② open to return the oil at the brake ports in the motors to the hydraulic oil tank.
- The oil which flowed into the pump charging circuit enters port **C**<sub>2</sub> of the rear pump and then port **C**<sub>1</sub> of the front pump through the pump's piping and supplies the amount of oil required by the main pump.  
The hydraulic pressure in the charging circuit is set to 16 – 18 kg/cm<sup>2</sup> by the charge relief valve (13) built into the main pump.  
If the pump charging circuit pressure drops below 9.5 kg/cm<sup>2</sup>, the low-pressure switch (10) is activated to warn the operator by flashing the warning lamp in order to prevent pump seizure.
- The main pumps (11) and (12) change the swash plate angle by means of the pump control valve (14) interlocked with the travel lever to adjust forward, reverse, and discharge, and send oil to the traveling motors.
- The travel motors (15) and (16) turn according to the amount of oil sent from the main pump and their speed is reduced by the reduction gear to drive the sprocket for running or turning the vehicle. A high-pressure relief valve (19) is built into the travel motor to set the main pump's discharging pressure. In addition, a flushing valve (combination of a shuttle valve (17) and a charge relief valve (18)) is built into the MST-800, 1100, and 1500. It relieves the oil of the circuit which became the travel motor's discharging side (low-pressure side) to the oil cooler (22) to prevent overheating and clean hydraulic oil of the HST circuit.

# HYDRAULIC CIRCUIT DIAGRAM (MST-1500, 2000)

MST-1500 Serial No. 15093 –  
MST-2000 Serial No. M02101 –,K20101 –

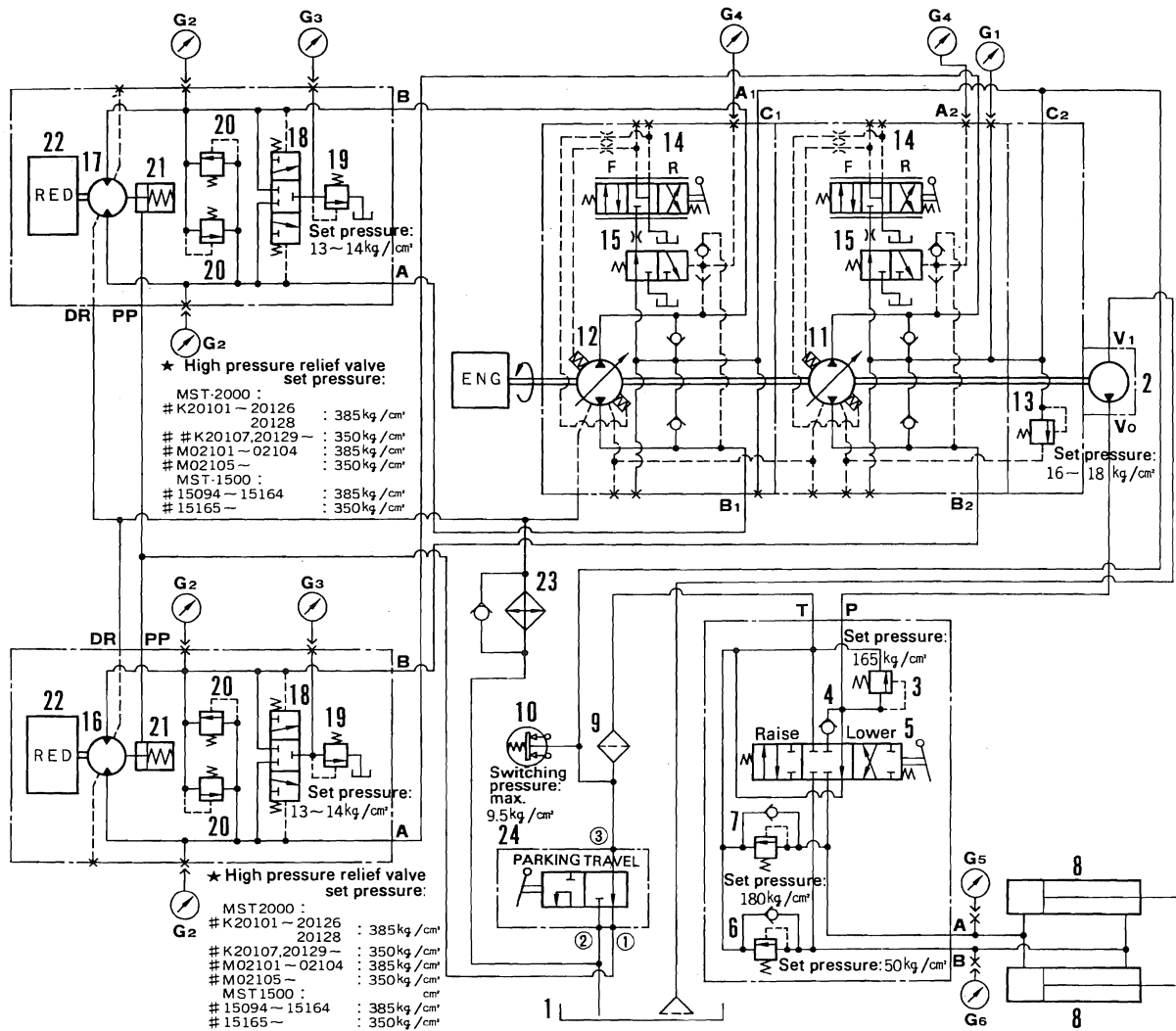

1. Hydraulic oil tank
2. Charging pump
3. Main relief valve
4. Check valve
5. Dump control valve
6. Over-load relief valve (Lower side)
7. Over-load relief valve (Raise side)
8. Dump cylinder
9. Hydraulic line filter
10. Low-pressure switch
11. Rear main pump (for left traveling)
12. Front main pump (for right traveling)
13. Charging relief valve
14. Pump control valve
15. Pressure override valve

16. Travel motor (for left traveling)
17. Travel motor (for right traveling)
18. Shuttle valve
19. Charging relief valve
20. High-pressure relief valve
21. Parking brake
22. Final drive
23. Oil cooler
24. Parking brake valve

- G<sub>1</sub>. Plug for charging pressure of main pump  
G<sub>2</sub>. Plug for high-pressure of main pump  
G<sub>3</sub>. Plug for charging pressure of travel motor  
G<sub>4</sub>. Plug for charging pressure of pressure override valve  
G<sub>5</sub>. Plug for main relief pressure of dump circuit  
G<sub>6</sub>. Plug for over-load relief pressure of dump circuit

## OIL FLOW

- Oil in the hydraulic oil tank (1) is sucked up by charging pump (2) and enters port P of the control valve (5).  
If the control valve (5) is at the "HOLD" position, the oil which entered port P goes out of port T and flows completely to the HST circuit.  
If the control valve (5) is in an operating condition, it flows to the dump cylinder circuit.
- If the dump lever is at the "RAISE" or "LOWER" position, oil of the dump cylinder circuit opens the check valve (4), comes out of port A or B through the spool, enters bottom side or head side of the dump cylinder (8) and makes the dump body raise or lower. The oil which is returned to the cylinder is cleaned as it passes port T and the line filter (9) and flows to the HST circuit. The dump body raising pressure is set to 165 kg/cm<sup>2</sup> by the main relief valve (3).  
The dump body lowering circuit pressure is set to 50 kg/cm<sup>2</sup> by the over-load relief valve (6).
- If the control valve (5) is at the "HOLD" position, oil of the HST circuit flows completely through two circuits of the pump charging and parking brake release.
- The oil which flowed into the parking brake release circuit enters port ③ of the parking brake valve (24). If the parking brake lever is at the "TRAVEL" position, the oil which entered port ③ comes out of port ①, enters the brake port provided in the right and left travel motors and "releases" the parking brake (21).  
If the parking brake lever is at the "PARK" position, the port ③ and port ① of the parking brake valve close and the port ① and port ② open to return the oil at the brake ports in the motors to the hydraulic oil tank.
- The oil which flowed into the pump charging circuit enters port C<sub>1</sub> of the rear pump and then port C<sub>2</sub> of the front pump through the pump's piping and supplies the amount of oil required by the main pump.  
The hydraulic pressure in the charging circuit is set to 16 – 18 kg/cm<sup>2</sup> by the charge relief valve (13) built into the main pump.  
If the pump charging circuit pressure drops below 9.5 kg/cm<sup>2</sup>, the low-pressure switch (10) is activated to warn the operator by flashing the warning lamp in order to prevent pump seizure.
- The main pumps (11) and (12) change the swash plate angle by means of the pump control valve (14) interlocked with the travel lever to adjust forward, reverse, and discharge, and send oil to the traveling motors.  
A pressure override valve (15) is built into the main pump. In the case of the main pump's discharging pressure reaching a continuous high-pressure relief condition, it shuts the oil flow to pump control valve (14) to return the main pump's swash plate angle to the neutral position. As the discharging pressure drops, the HST circuit is protected.
- The travel motors (16) and (17) turn according to the amount of oil sent from the main pump and their speed is reduced by the reduction gear to drive the sprocket for running or turning the vehicle. A high-pressure relief valve (20) is built into the travel motor to set the main pump's discharging pressure.  
In addition, a flushing valve (combination of a shuttle valve (18) and a charge relief valve (19)) is built into the MST-1500 and 2000. It relieves the oil of the circuit which became the travel motor's discharging side (low-pressure side) to the oil cooler (23) to prevent overheating and clean hydraulic oil of the HST circuit.

# HYDRAULIC CIRCUIT DIAGRAM (MST-2200)

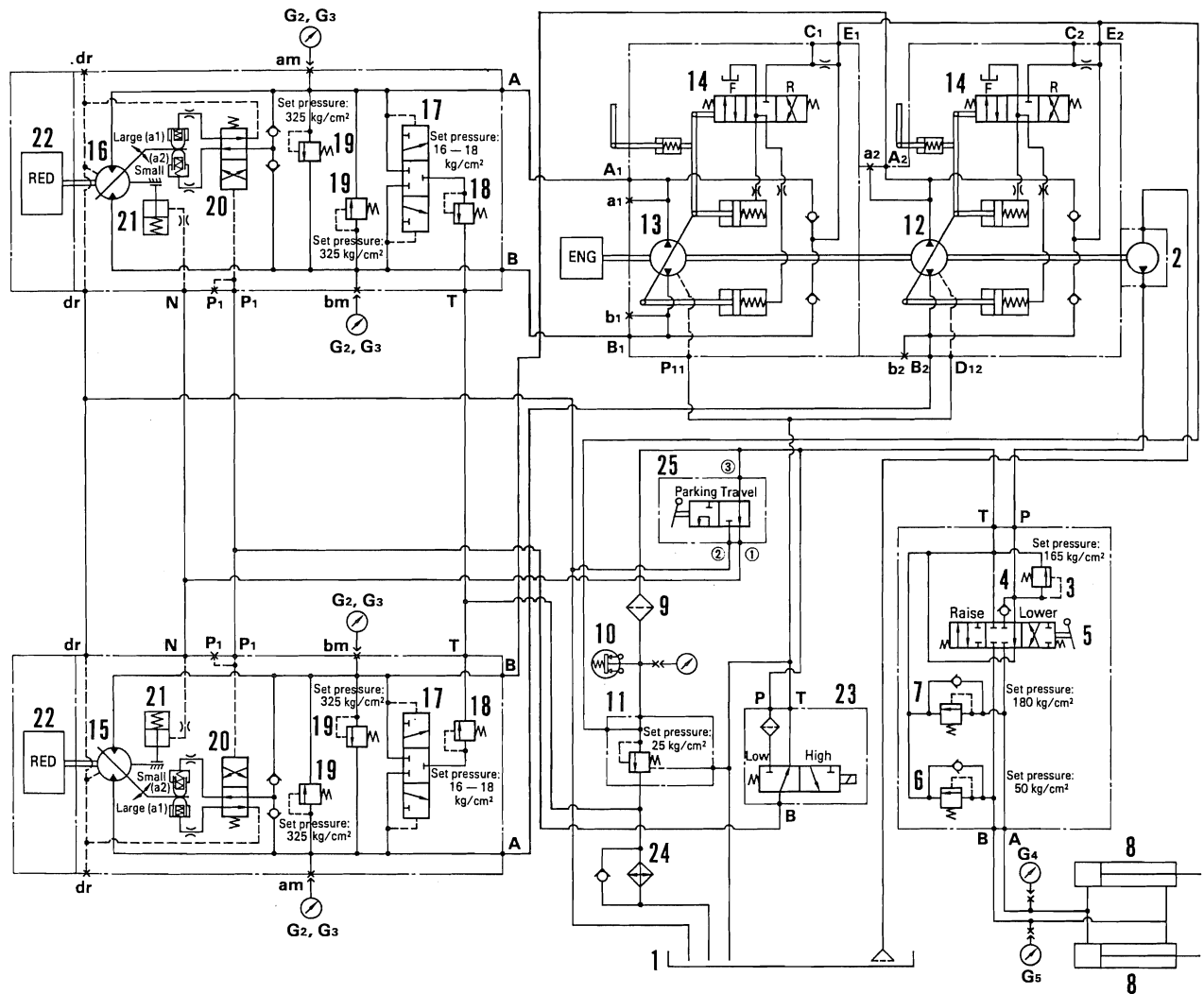

- |   |  |
|---|--|
| 1. Hydraulic oil tank                     | 16. Travel motor (for right traveling) |
| 2. Charging pump                          | 17. Shuttle valve                      |
| 3. Main relief valve                      | 18. Charging relief valve              |
| 4. Check valve                            | 19. High-pressure relief valve         |
| 5. Dump control valve                     | 20. H-L speed changing valve           |
| 6. Over-load relief valve (Lower side)    | 21. Parking brake                      |
| 7. Over-load relief valve (Raise side)    | 22. Final drive                        |
| 8. Dump cylinder                          | 23. H-L speed changing solenoid valve  |
| 9. Hydraulic line filter                  | 24. Oil cooler                         |
| 10. Low-pressure switch                   | 25. Parking brake valve                |
| 11. Charging relief valve                 |  |
| 12. Rear main pump (for left traveling)   |  |
| 13. Front main pump (for right traveling) |  |
| 14. Pump control valve                    |  |
| 15. Travel motor (for left traveling)     |  |

- G<sub>1</sub>. Plug for charging pressure of main pump  
 G<sub>2</sub>. Plug for high-pressure of main pump  
 G<sub>3</sub>. Plug for charging pressure of travel motor  
 G<sub>4</sub>. Plug for main relief pressure of dump circuit  
 G<sub>5</sub>. Plug for over-load relief pressure of dump circuit

## OIL FLOW

- Oil in the hydraulic oil tank (1) is sucked up by charging pump (2) and enters port **P** of the control valve (5).

If the control valve (5) is at the "HOLD" position, the oil which entered port **P** goes out of port **T** and flows completely to the HST circuit.

If the control valve (5) is in an operating condition, it flows to the dump cylinder circuit.

- If the dump lever is at the "RAISE" or "LOWER" position, oil of the dump cylinder circuit opens the check valve (4), comes out of port **A** or **B** through the spool, enters bottom side or head side of the dump cylinder (8) and makes the carrier raise or lower.

The oil which is returned to the cylinder is cleaned as it passes port **T** and the line filter (9) and flows to the HST circuit. The dump body raising pressure is set to 165 kg/cm<sup>2</sup> by the main relief valve (3).

The dump body lowering pressure is set to 50 kg/cm<sup>2</sup> by the over-load relief valve (6).

- When control valve (5) is at the "HOLD" position, the oil in the HST circuit is all divided into three circuits and flows through the pump charge, travel motor high/low speed selector, and parking brake release circuits.

- The oil which flowed into the parking brake release circuit enters port (3) of the parking brake valve (25). If the parking brake lever is at the "TRAVEL" position, the oil which entered port (3) comes out of port (1), enters the brake port provided in the right and left travel motors and "releases" the parking brake (21).

If the parking brake lever is at the "PARK" position, the port (3) and port (1) of the parking brake valve close and the port (1) and port (2) open to return the oil at the brake ports in the motors to the hydraulic oil tank.

- The oil flowing through the travel motor high/low speed selector circuit enters port **P** of solenoid selector valve (23).

If the high/low speed selector switch in the operator's compartment is at the LOW SPEED position, the solenoid selector valve is not actuated. The circuit of ports **P** and **B** is closed, so the oil entering port **P** flows to other circuits. At the same time, the solenoid selector valve opens the circuit of ports **B** and **T**, so the pilot pressure (oil) at high/low speed selector valve (20) inside the motor is returned to the hydraulic tank, and the motor runs at low speed.

When the high/low speed selector switch in the operator's compartment is at the HIGH SPEED position, the solenoid selector valve is actuated, the circuit of ports **P** and **B** is opened, and the circuit of ports **B** and **T** is closed. When this happens, the oil entering port **P** flows from port **P** to port **B**, and

becomes the pilot pressure of the high/low speed selector valve inside the travel motor. This switches the valve, and the motor runs at high speed.

In other words, the solenoid selector valve switches the pilot pressure that controls the high/low speed selector valve inside the travel motor, and the high/low speed selector valve inside the travel motor switches the high pressure oil from the main pump and controls the swash plate angle of the travel motor.

- The oil flowing to the pump charge circuit passes through pump charge relief valve (11) at the rear of the operator's compartment, enters port **E**<sub>2</sub> of the rear pump, then enters port **E**<sub>1</sub> of the front pump, and supplies the required amount of oil for the main pump.

The pressure in the charge circuit is set to 25 kg/cm<sup>2</sup> by the charge relief valve.

If the pressure in the pump charge circuit drops below 9.5 kg/cm<sup>2</sup>, low pressure switch (10) is actuated, and the caution lamp lights up to prevent seizure of the pump.

- The swash plate angle of main pumps (12) and (13) is changed by pump control valve (14) that is interconnected with the travel lever. It adjusts the direction of rotation (normal or reverse), and the discharge amount, and sends the oil to the travel motor.

- Travel motors (15) and (16) rotate in accordance with the amount of oil sent from the main pumps. This rotation is reduced by the reduction gear, and goes on to drive the sprocket to drive or turn the machine. Furthermore, high/low speed selector valve (20) is built into the travel motor. It is actuated by the pilot pressure from high/low speed solenoid selector valve (23), sends the oil at the high pressure side of the travel motor to the swash plate angle selector cylinder, and changes the swash plate angle of the travel motor to set the maximum level for the rotating speed. In other words, the travel motor has two stages.

In addition, the travel motor also has a built-in flushing valve [a combination of shuttle valve (17) and charge relief valve (18)], and this relieves the oil in the circuit at the discharge side (low pressure side) of the travel motor, sends it to oil cooler (24), and cleans the oil in the HST circuit while preventing the oil from overheating.

# HYDRAULIC CIRCUIT DIAGRAM (MST-2500)

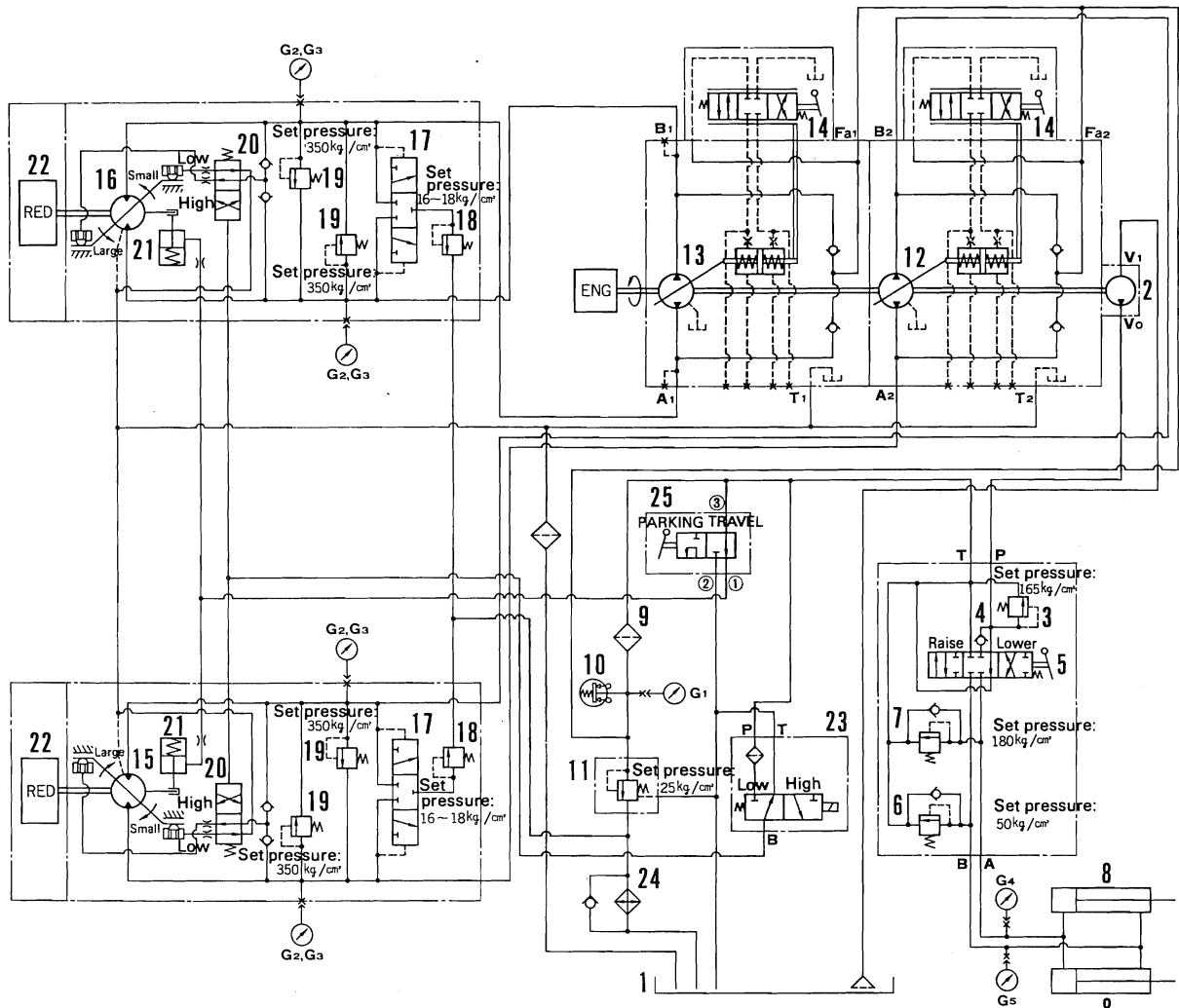

- |   |  |
|---|--|
| 1. Hydraulic oil tank                     | 16. Travel motor (for right traveling)                         |
| 2. Charging pump                          | 17. Shuttle valve  |
| 3. Main relief valve                      | 18. High-pressure relief valve                                 |
| 4. Check valve                            | 19. Charging relief valve                                      |
| 5. Dump control valve                     | 20. H-L speed changing valve                                   |
| 6. Over-load relief valve (Lower side)    | 21. Parking brake  |
| 7. Over-load relief valve (Raise side)    | 22. Final drive  |
| 8. Dump cylinder                          | 23. H-L speed changing solenoid valve                          |
| 9. Hydraulic line filter                  | 24. Oil cooler   |
| 10. Low-pressure switch                   | 25. Parking brake valve  |
| 11. Charging relief valve                 |  |
| 12. Rear main pump (for left traveling)   | G <sub>1</sub> . Plug for charging pressure of main pump       |
| 13. Front main pump (for right traveling) | G <sub>2</sub> . Plug for high-pressure of main pump           |
| 14. Pump control valve                    | G <sub>3</sub> . Plug for charging pressure of travel motor    |
| 15. Travel motor (for left traveling)     | G <sub>4</sub> . Plug for main relief pressure of dump circuit |

## OIL FLOW

- Oil in the hydraulic oil tank (1) is sucked up by charging pump (2) and enters port P of the control valve (5).

If the control valve (5) is at the "HOLD" position, the oil which entered port P goes out of port T and flows completely to the HST circuit.

If the control valve (5) is in an operating condition, it flows to the dump cylinder circuit.

- If the dump lever is at the "RAISE" or "LOWER" position, oil of the dump cylinder circuit opens the check valve (4), comes out of port A or B through the spool, enters bottom side or head side of the dump cylinder (8) and makes the carrier raise or lower.

The oil which is returned to the cylinder is cleaned as it passes port T and the line filter (9) and flows to the HST circuit. The dump body raising pressure is set to 165 kg/cm<sup>2</sup> by the main relief valve (3).

The dump body lowering pressure is set to 50 kg/cm<sup>2</sup> by the over-load relief valve (6).

- When control valve (5) is at the "HOLD" position, the oil in the HST circuit is all divided into three circuits and flows through the pump charge, travel motor high/low speed selector, and parking brake release circuits.
- The oil which flowed into the parking brake release circuit enters port ③ of the parking brake valve (25). If the parking brake lever is at the "TRAVEL" position, the oil which entered port ③ comes out of port ①, enters the brake port provided in the right and left travel motors and "releases" the parking brake (21).

If the parking brake lever is at the "PARK" position, the port ③ and port ① of the parking brake valve close and the port ① and port ② open to return the oil at the brake ports in the motors to the hydraulic oil tank.

- The oil flowing through the travel motor high/low speed selector circuit enters port P of solenoid selector valve (23).

If the high/low speed selector switch in the operator's compartment is at the LOW SPEED position, the solenoid selector valve is not actuated. The circuit of ports P and B is closed, so the oil entering port P flows to other circuits. At the same time, the solenoid selector valve opens the circuit of ports B and T, so the pilot pressure (oil) at high/low speed selector valve (20) inside the motor is returned to the hydraulic tank, and the motor runs at low speed.

When the high/low speed selector switch in the operator's compartment is at the HIGH SPEED position, the solenoid selector valve is actuated, the circuit of ports P and B is opened, and the circuit of ports B and T is closed. When this happens, the oil entering port P flows from port P to port B, and

becomes the pilot pressure of the high/low speed selector valve inside the travel motor. This switches the valve, and the motor runs at high speed.

In other words, the solenoid selector valve switches the pilot pressure that controls the high/low speed selector valve inside the travel motor, and the high/low speed selector valve inside the travel motor switches the high pressure oil from the main pump and controls the swash plate angle of the travel motor.

- The oil flowing to the pump charge circuit passes through pump charge relief valve (11) at the rear of the operator's compartment, enters port Fa<sub>2</sub> of the rear pump, then enters port Fa<sub>1</sub> of the front pump, and supplies the required amount of oil for the main pump.

The pressure in the charge circuit is set to 25 kg/cm<sup>2</sup> by the charge relief valve.

If the pressure in the pump charge circuit drops below 9.5 kg/cm<sup>2</sup>, low pressure switch (10) is actuated, and the caution lamp lights up to prevent seizure of the pump.

- The swash plate angle of main pumps (12) and (13) is changed by pump control valve (14) that is interconnected with the travel lever. It adjusts the direction of rotation (normal or reverse), and the discharge amount, and sends the oil to the travel motor.
- Travel motors (15) and (16) rotate in accordance with the amount of oil sent from the main pumps. This rotation is reduced by the reduction gear, and goes on to drive the sprocket to drive or turn the machine. Furthermore, high/low speed selector valve (20) is built into the travel motor. It is actuated by the pilot pressure from high/low speed solenoid selector valve (23), sends the oil at the high pressure side of the travel motor to the swash plate angle selector cylinder, and changes the swash plate angle of the travel motor to set the maximum level for the rotating speed. In other words, the travel motor has two stages.

In addition, the travel motor also has a built-in flushing valve [a combination of shuttle valve (17) and charge relief valve (18)], and this relieves the oil in the circuit at the discharge side (low pressure side) of the travel motor, sends it to oil cooler (24), and cleans the oil in the HST circuit while preventing the oil from overheating.



# HYDRAULIC PUMP (MST-500)

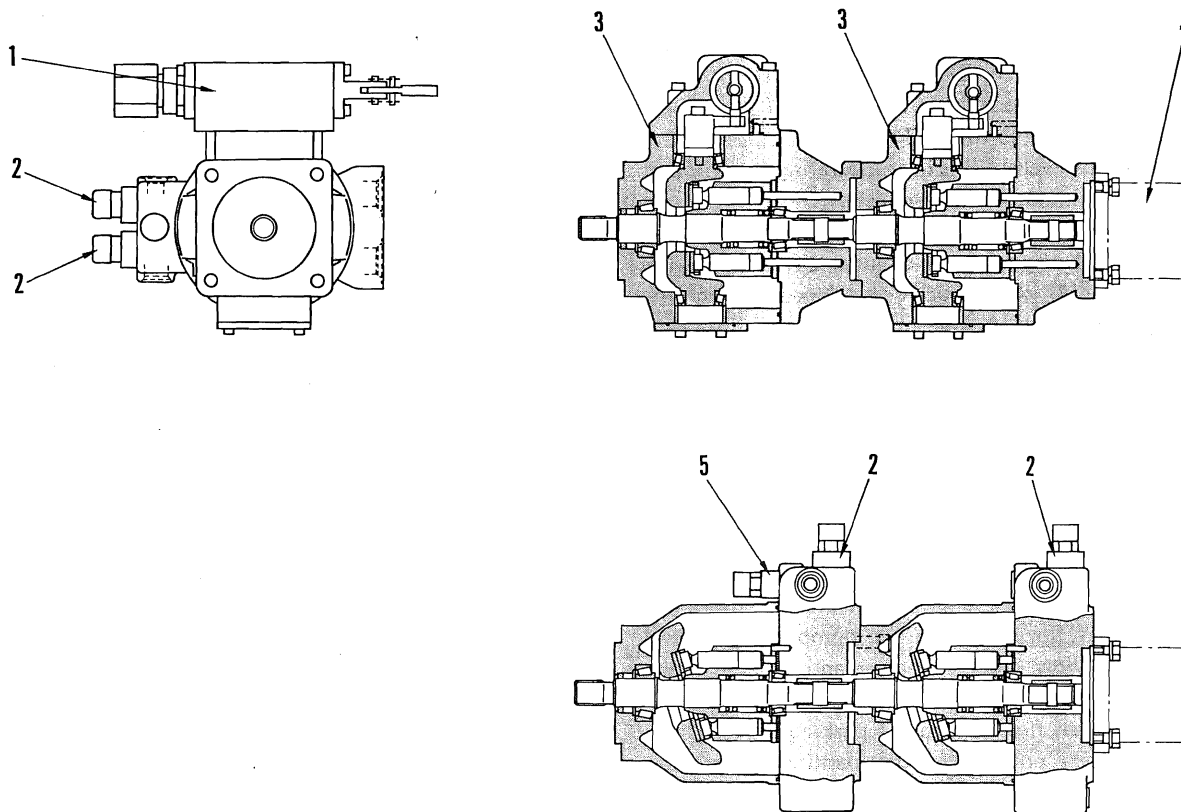

1. Pump control valve
2. High-pressure relief valve
3. Main pump
4. Charging pump
5. Charging relief valve

## GENERAL

- The hydraulic pumps are mounted in the rear part of the engine via a rubber coupling; they are 2 sets of tandem main pumps and a gear-type pump to supply oil to the charging and work equipment circuits, making up triple pumps.

Swash plate-type main pumps are adopted.

- The table below shows the main pump's discharging and charging pressure.

Model	Pump discharge (cc/rev)	Charging pressure (kg/cm <sup>2</sup> )
MST-500	43.0	20

# HYDRAULIC PUMP (MST-600 — 1500)

MST-600 Serial No. 1601 —  
 MST-700 Serial No. 70101 —  
 MST-800 Serial No. 866 —  
 MST-1100 Serial No. M01101 —, K11101 —  
 MST-1500 Serial No. 15001 — 15093

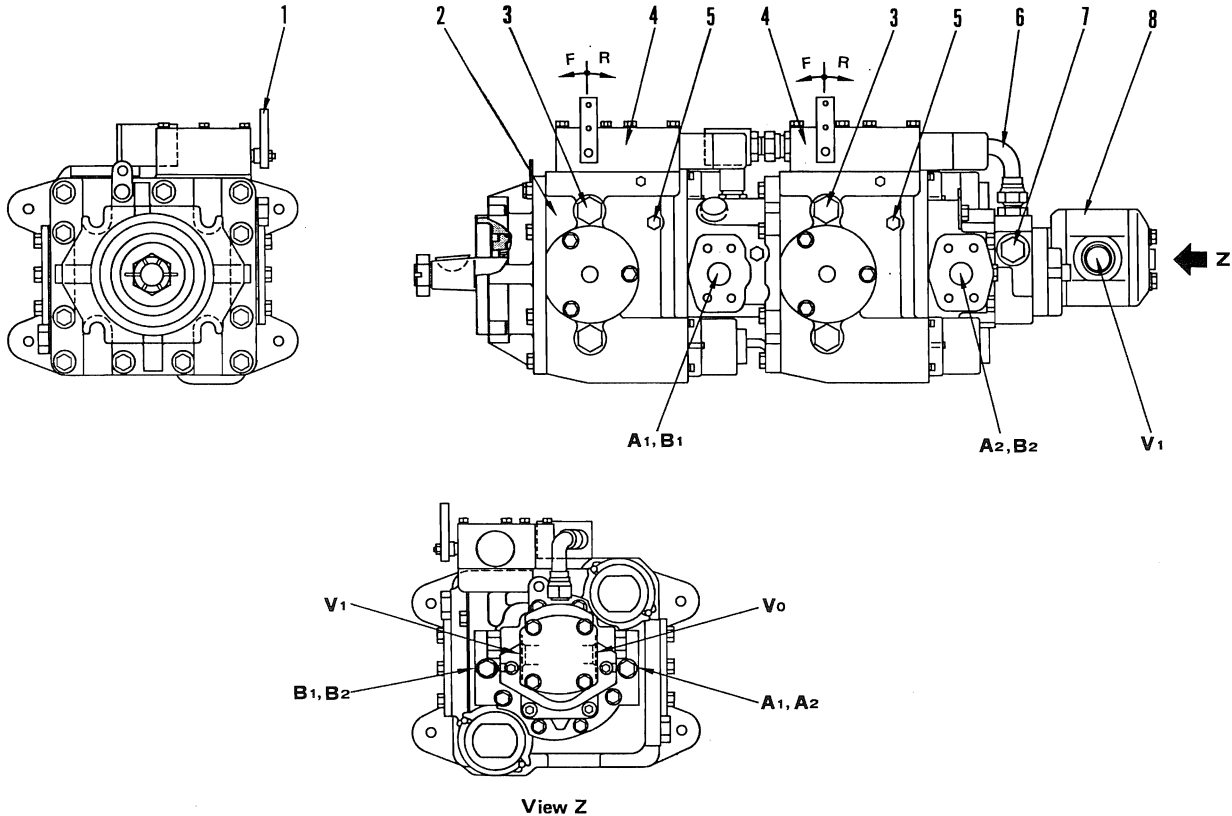

1. Control lever
2. Main pump
3. Drain plug (7/8-14UNF)
4. Pump control valve
5. Plug for charging pressure (7/16-20UNF)
6. Tube (connecting front and rear charging ports)
7. Plug (right side is charging relief valve)
8. Charging pump

A<sub>1</sub>. To port B of right travel motor (Forward)  
 B<sub>1</sub>. To port A of right travel motor (Reverse)  
 A<sub>2</sub>. To port B of left travel motor (Forward)  
 B<sub>2</sub>. To port A of left travel motor (Reverse)  
 V<sub>0</sub>. To main pump charging and dump circuits  
 V<sub>1</sub>. From hydraulic tank

## GENERAL

- The hydraulic pumps are mounted in the rear part of the engine via a rubber coupling; they are 2 sets of tandem main pumps and a gear-type pump to supply oil to the charging and work equipment circuits, making up triple pumps.  
Swash plate-type main pumps are adopted.
- The table below shows the main pump's discharging and charging pressure.

Model	Pump discharge (cc/rev)	Charging pressure (kg/cm <sup>2</sup> )
MST-600	51.6	16-18
MST-700	51.6	16-18
MST-800	51.6	16-18
MST-1100	51.6	16-18
MST-1500	69.8	16-18

# HYDRAULIC PUMP (MST-1500, 2000)

MST-1500 Serial No. 15094 —  
 MST-2000 Serial No. M02101 —, K20101 —

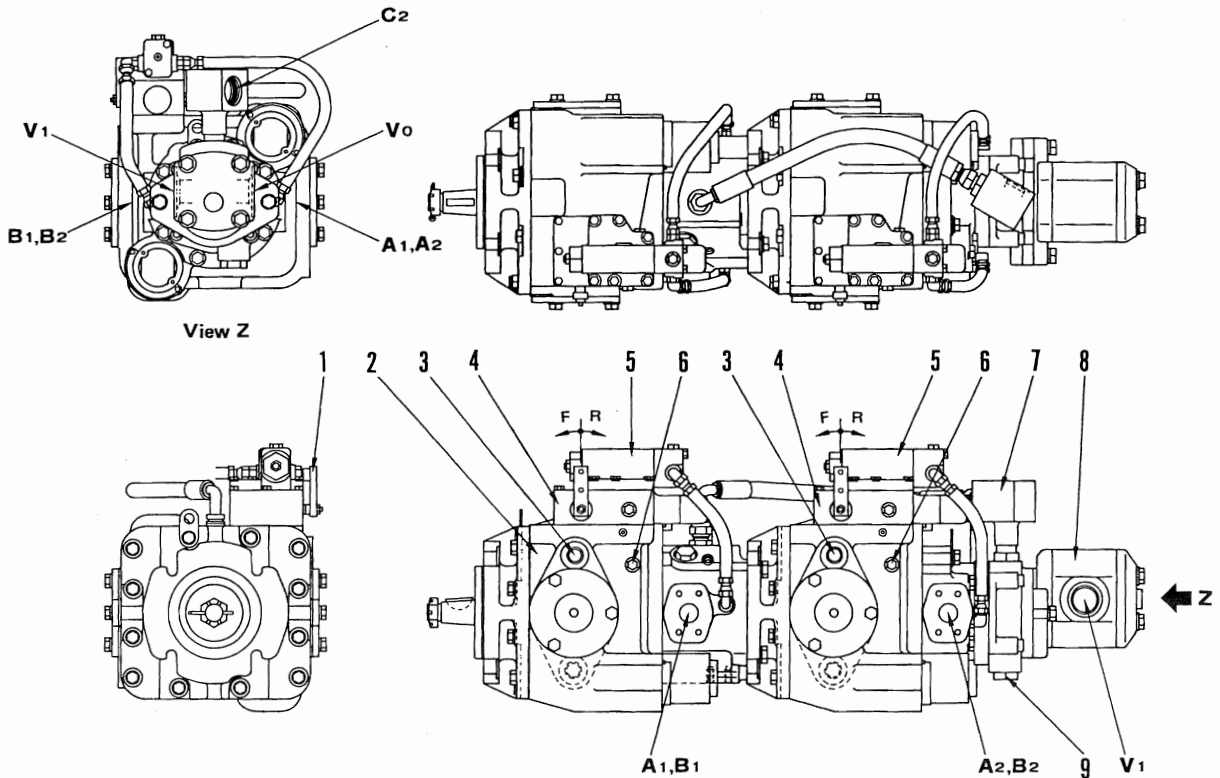

1. Control lever
2. Main pump
3. Drain plug (7/8-14UNF)
4. Pump control valve
5. Pressure override valve
6. Plug for charging pressure (7/16-20UNF)
7. Tube (connecting front and rear charging ports)
8. Charging pump
9. Charging relief valve

A<sub>1</sub>. To port B of right travel motor (Forward)  
 B<sub>1</sub>. To port A of right travel motor (Reverse)  
 A<sub>2</sub>. To port B of left travel motor (Forward)  
 B<sub>2</sub>. To port A of left travel motor (Reverse)  
 V<sub>0</sub>. To main pump charging and dump circuits  
 V<sub>1</sub>. From hydraulic tank

## GENERAL

- The hydraulic pumps are mounted in the rear part of the engine via a rubber coupling; they are 2 sets of tandem main pumps and a gear-type pump to supply oil to the charging and work equipment circuits, making up triple pumps.

Swash plate-type main pumps are adopted.

The pressure override valve is provided in the circuit between the charge relief valve and the pump control valve. If the main pump discharging pressure becomes continuously high, it shuts the oil flow to the pump control valve to return the pump's swash plate angle to the "NEUTRAL" position. As the main pump's discharge is stopped, the pressure drops to protect the traveling motors and the piping from abnormally high pressure.

- The table below shows the main pump's discharge and charging pressure.

Model	Pump discharge (cc/rev)	Charging pressure (kg/cm <sup>2</sup> )
MST-1500	69.8	16-18
MST-2000	89.0	16-18

# DETAIL DRAWING OF HYDRAULIC PUMP

MST-600, 700, 800, 1100  
MST-1500 Serial No. 15001-15093

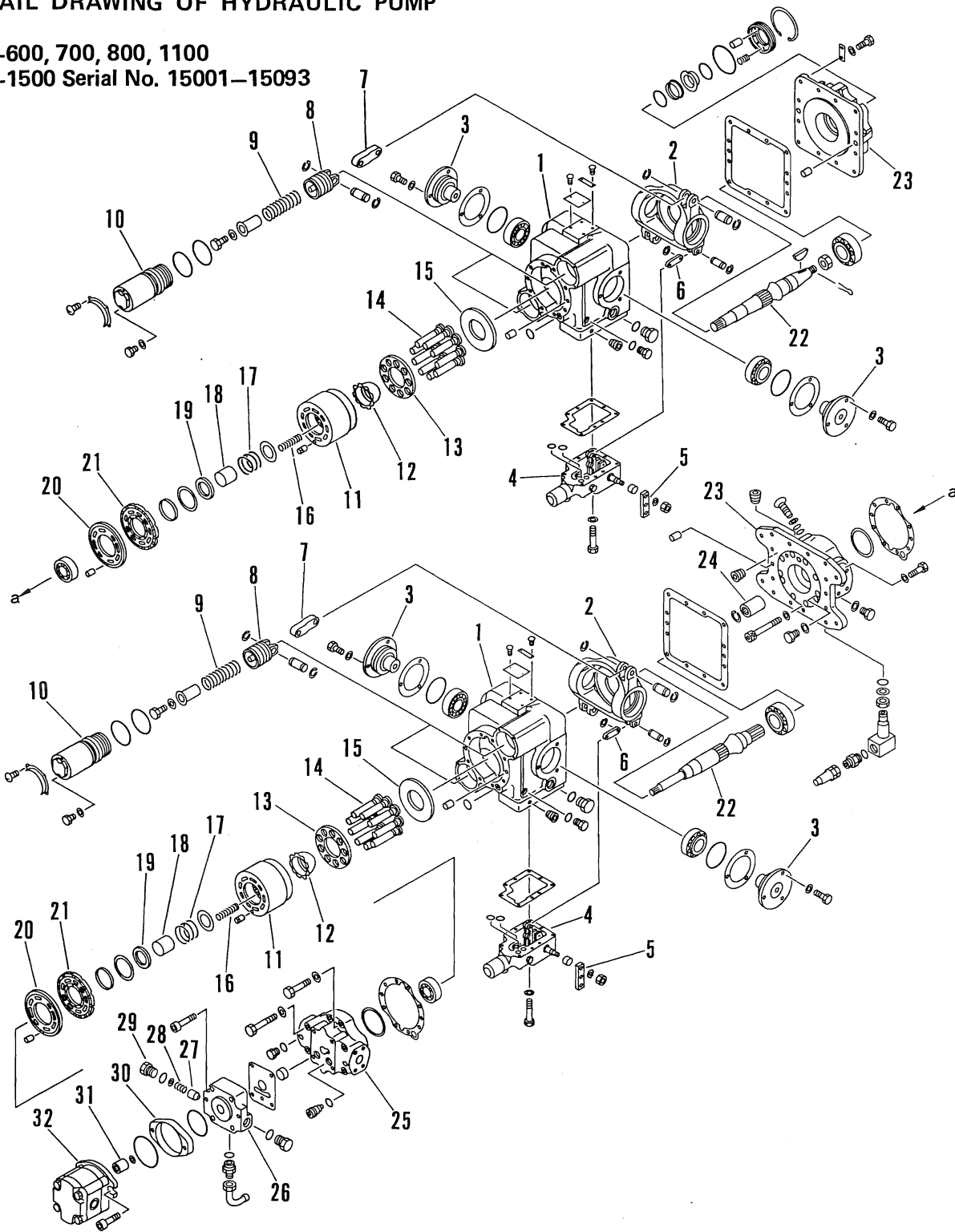

- |                  |                    |                   |                           |
|------------------|--------------------|-------------------|---------------------------|
| 1. Housing       | 9. Spring          | 17. Spring        | 25. Housing               |
| 2. Yoke          | 10. Sleeve         | 18. Guide         | 26. Housing               |
| 3. Trunnion      | 11. Cylinder block | 19. Retainer      | 27. Charging valve poppet |
| 4. Control valve | 12. Guide          | 20. Swash plate   | 28. Spring                |
| 5. Control lever | 13. Retainer       | 21. Bearing plate | 29. Spring                |
| 6. Link          | 14. Piston         | 22. Drive shaft   | 30. Support               |
| 7. Link          | 15. Thrust plate   | 23. Housing       | 31. Coupling              |
| 8. Yoke          | 16. Spring         | 24. Coupling      | 32. Charging pump         |

# DETAIL DRAWING OF HYDRAULIC PUMP

MST-1500 Serial No. 15094 —

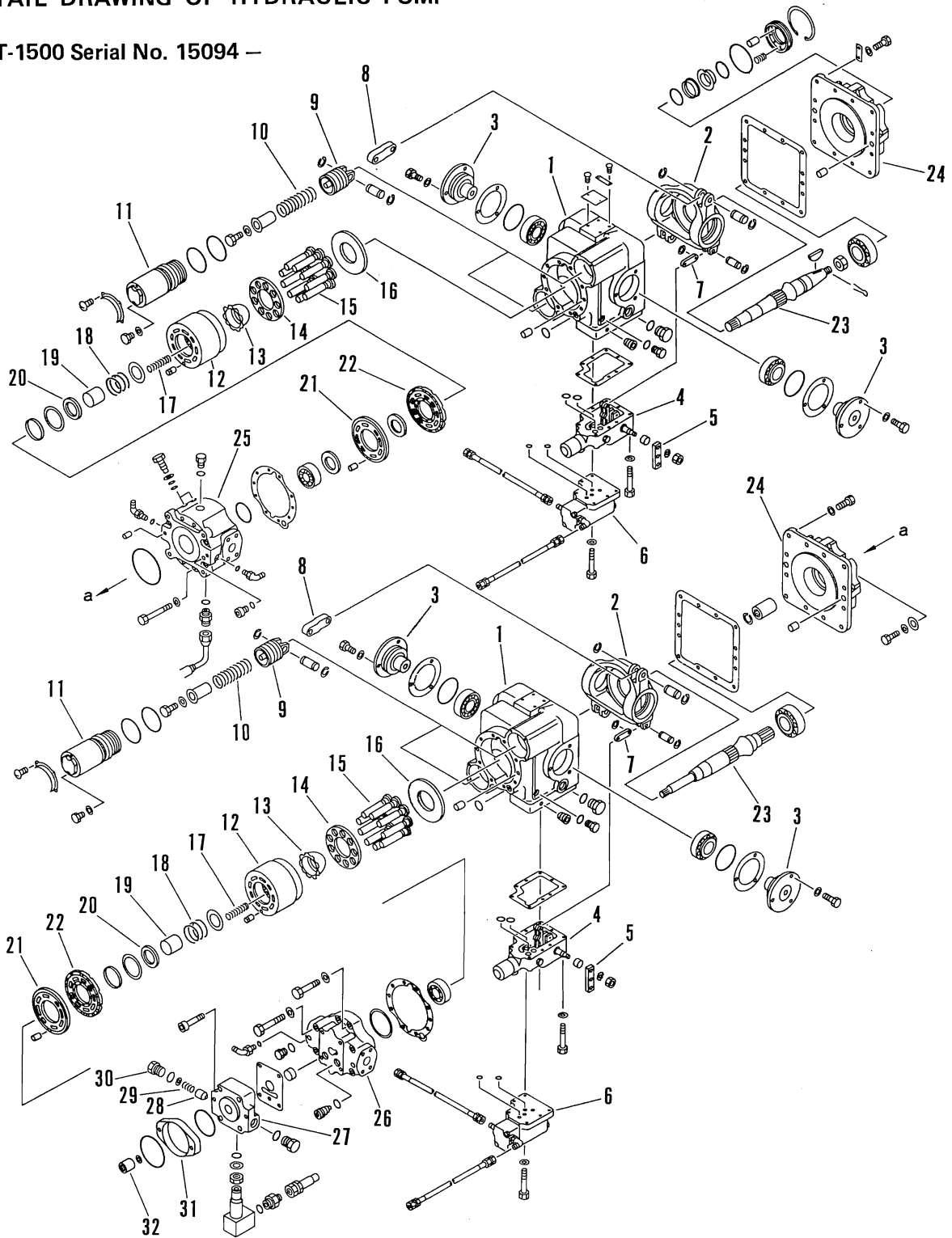

1. Housing

2. Yoke

3. Trunnion

4. Control valve

5. Control lever

6. Pressure override valve

7. Link

8. Link

9. Yoke

10. Spring

11. Sleeve

12. Cylinder block

13. Guide

14. Retainer

15. Piston

16. Thrust plate

17. Spring

18. Spring

19. Guide

20. Retainer

21. Swash plate

22. Bearing plate

23. Drive shaft

24. Housing

25. Housing

26. Housing

27. Housing

28. Charging valve poppet

29. Spring

30. Plug

31. Support

32. Coupling

# DETAIL DRAWING OF HYDRAULIC PUMP

MST-2000

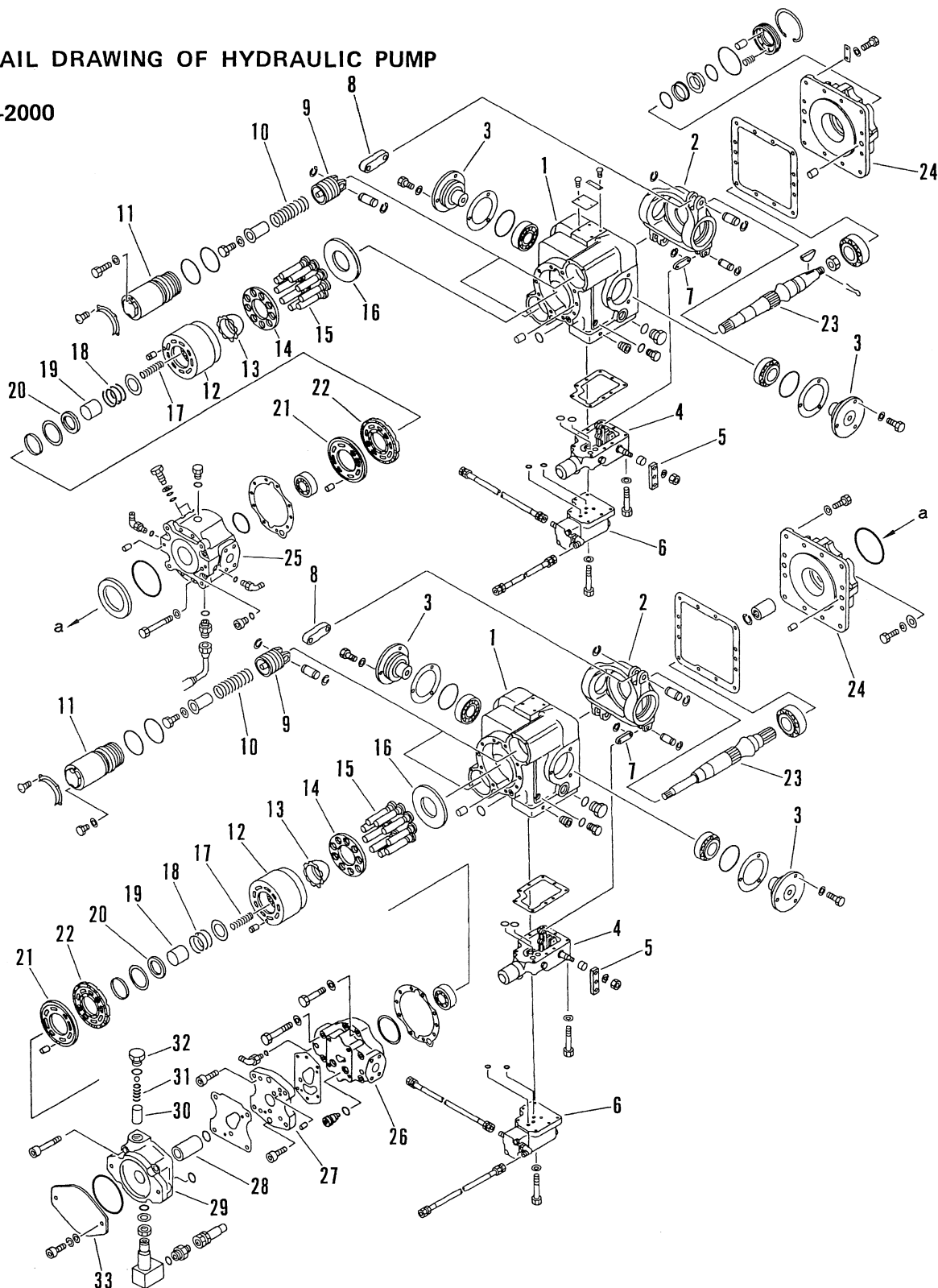

- |                            |                    |                   |                           |
|----------------------------|--------------------|-------------------|---------------------------|
| 1. Housing                 | 10. Spring         | 19. Guide         | 28. Coupling              |
| 2. Yoke                    | 11. Sleeve         | 20. Retainer      | 29. Housing               |
| 3. Trunnion                | 12. Cylinder block | 21. Swash plate   | 30. Charging valve poppet |
| 4. Control valve           | 13. Guide          | 22. Bearing plate | 31. Spring                |
| 5. Control lever           | 14. Retainer       | 23. Drive shaft   | 32. Plug                  |
| 6. Pressure override valve | 15. Piston         | 24. Housing       | 33. Cover                 |
| 7. Link                    | 16. Thrust plate   | 25. Housing       |                           |
| 8. Link                    | 17. Spring         | 26. Housing       |                           |
| 9. Yoke                    | 18. Spring         | 27. Plate         |                           |

## DETAIL DRAWING OF PUMP CONTROL VALVE

★ The diagram shows the MST-600, 700, 800, 1100, 1500 and 2000.

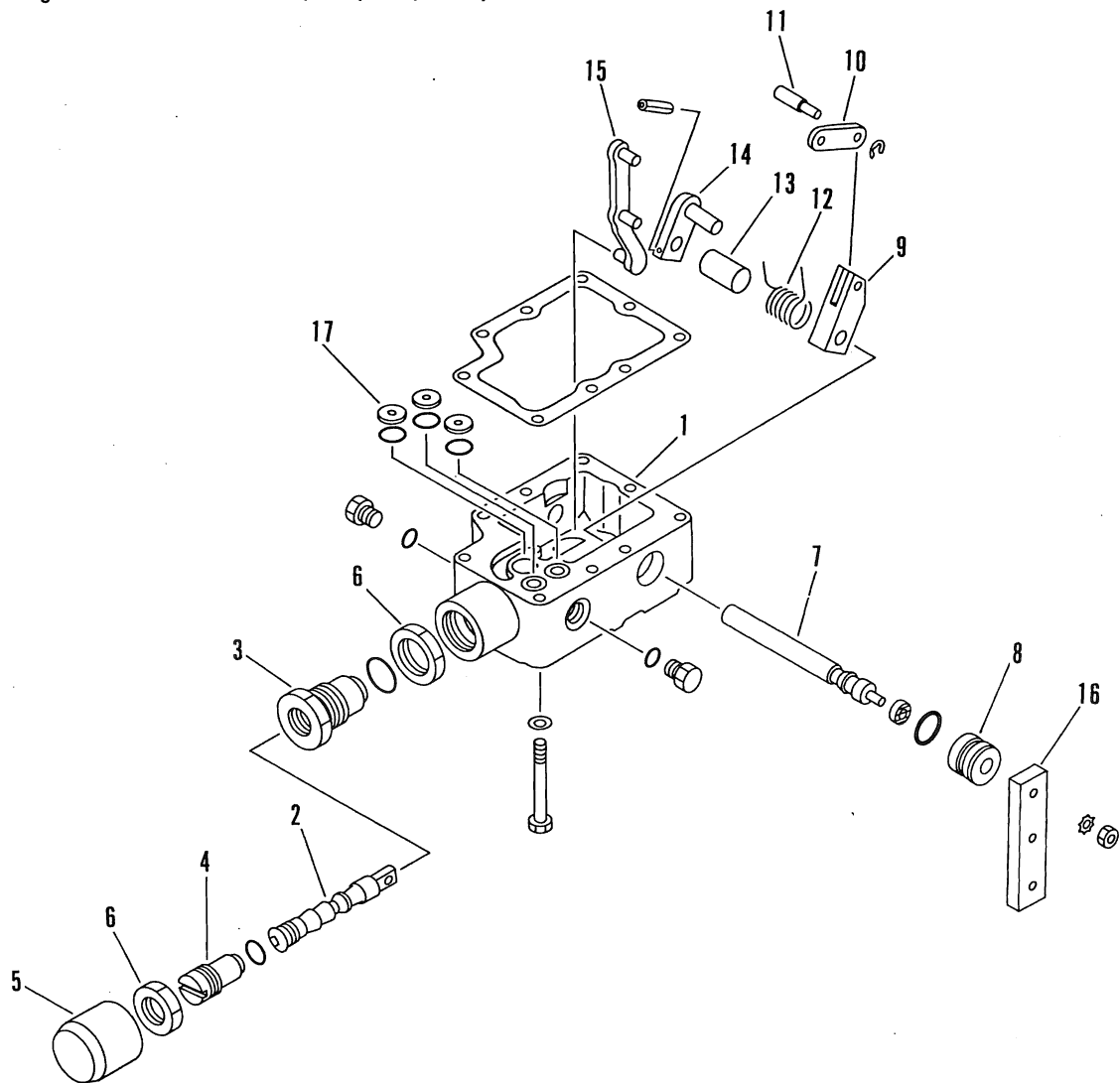

1. Valve housing
2. Valve spool
3. Sleeve
4. Adjustment screw
5. Cap
6. Lock nut
7. Shaft
8. Sleeve
9. Lever
10. Link
11. Shaft
12. Spring
13. Collar
14. Lever
15. Lever
16. Control lever
17. Orifice

### GENERAL

- The pump control valve is mounted in the upper part of either of the front or rear main pumps. Interlocked with the linkage from the steering lever, it controls the main pump's swash plate angle to control the vehicle's traveling speed and turning motion. The control valve switches the oil from the charging pump.

# HYDRAULIC PUMP (MST-2200)

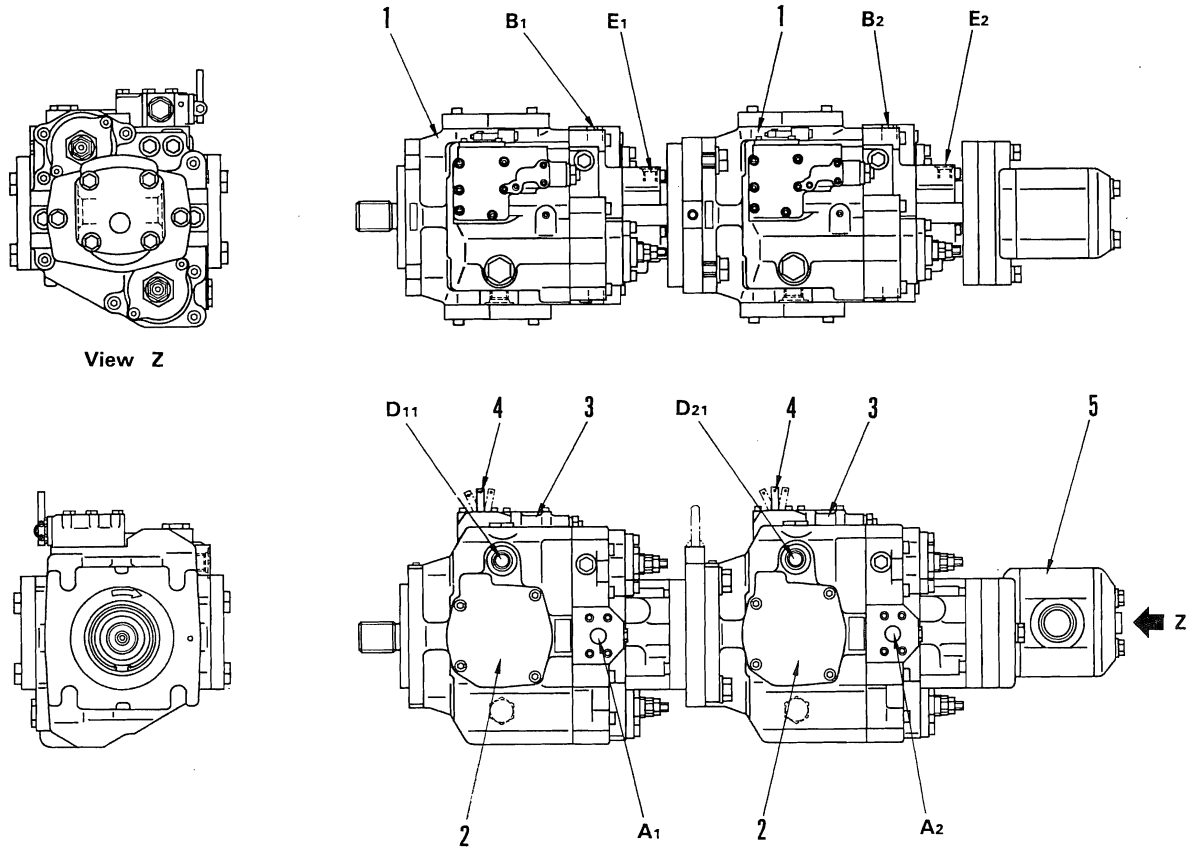

- 1. Main pump
- 2. Servo cylinder
- 3. Pump control valve
- 4. Control lever
- 5. Charging pump

- A<sub>1</sub>. To port B of right travel motor (Forward)
- B<sub>1</sub>. To port A of right travel motor (Reverse)
- A<sub>2</sub>. To port B of left travel motor (Forward)
- B<sub>2</sub>. To port A of left travel motor (Reverse)
- To main pump charging and dump circuits  
From hydraulic tank
- E<sub>1</sub>. From charging pump
- E<sub>2</sub>. From charging pump
- D<sub>11</sub>. To hydraulic tank
- D<sub>21</sub>. To hydraulic tank

## GENERAL

- The hydraulic pumps are mounted in the rear part of the engine via a rubber coupling; they are 2 sets of tandem main pumps and a gear-type pump to supply oil to the charging and work equipment circuits, making up triple pumps.

Swash plate-type main pumps are adopted.

Charge relief valve installed to the main pump has its actual function stopped, and the charge relief valve installed at the rear of the operator's compartment sets the pressure of the charge circuit.

- The table below shows the main pump's discharge and charging pressure.

Model	Pump discharge (cc/rev)	Charging pressure (kg/cm <sup>2</sup> )
MST-2200	110.9	25



# HYDRAULIC PUMP (MST-2500)

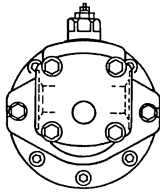

View Z

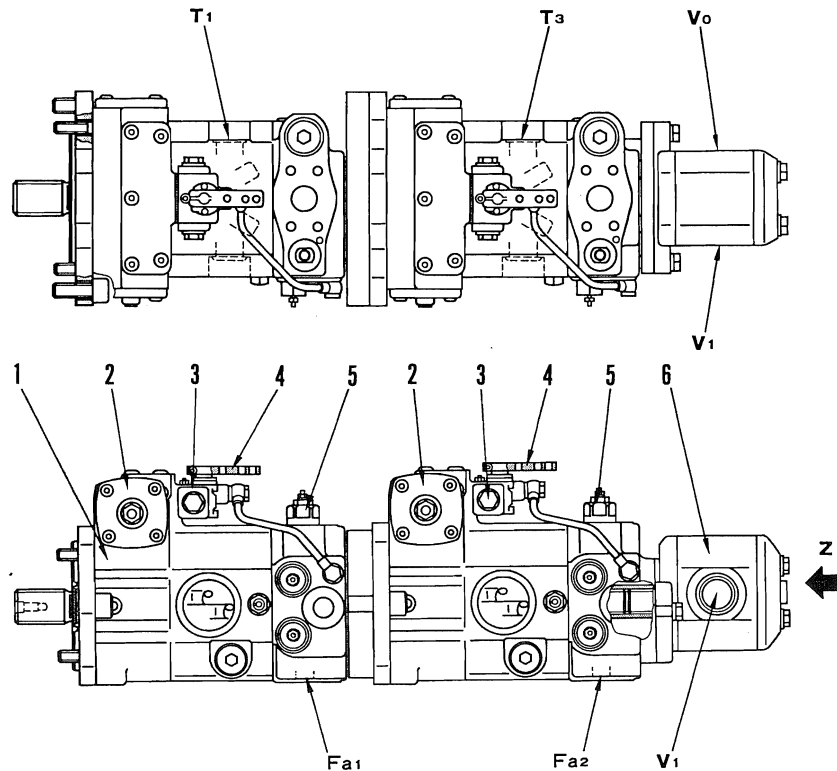
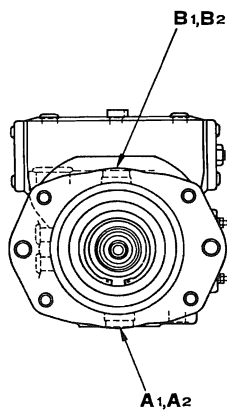

1. Main pump
2. Servo cylinder
3. Pump control valve
4. Control lever
5. Charging relief valve
6. Charging pump

- A<sub>1</sub>. To port B of right travel motor (Forward)  
 B<sub>1</sub>. To port A of right travel motor (Reverse)  
 A<sub>2</sub>. To port B of left travel motor (Forward)  
 B<sub>2</sub>. To port A of left travel motor (Reverse)  
 V<sub>0</sub>. To main pump charging and dump circuits  
 V<sub>1</sub>. From hydraulic tank  
 Fa<sub>1</sub>. From charging pump  
 Fa<sub>2</sub>. From charging pump  
 T<sub>1</sub>. To hydraulic tank  
 T<sub>3</sub>. To hydraulic tank

## GENERAL

- The hydraulic pumps are mounted in the rear part of the engine via a rubber coupling; they are 2 sets of tandem main pumps and a gear-type pump to supply oil to the charging and work equipment circuits, making up triple pumps. Swash plate-type main pumps are adopted. Charge relief valve (5) installed to the main pump has its actual function stopped, and the charge relief valve installed at the rear of the operator's compartment sets the pressure of the charge circuit.
- The table below shows the main pump's discharge and charging pressure.

Model	Pump discharge (cc/rev)	Charging pressure (kg/cm <sup>2</sup> )
MST-2500	125	25

# TRAVEL MOTOR (MST-500)

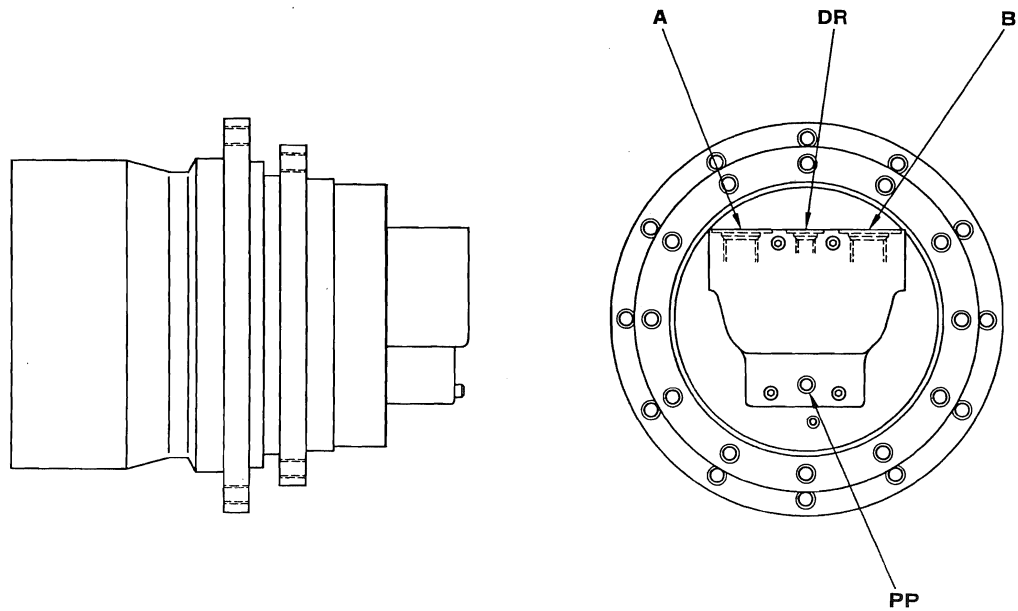

- A. From port A1 or A2 of main pump (Forward)
- B. From port B1 or B2 of main pump (Reverse)
- DR. To hydraulic tank
- PP. Port for parking brake

## GENERAL

- The travel motors are mounted in the right and left front of the main frame. They drive the sprocket to run or turn the vehicle. Swash plate-type travel motors are adopted. A parking disc brake and a planetary reduction gear are mounted.
- The table below shows the travel motor's discharge and high pressure relief pressure.

Model	Motor discharge (cc/rev)	Relief pressure (kg/cm <sup>2</sup> )	Max. output speed (rpm)	Brake pressure (kg/cm <sup>2</sup> )
MST-500	39.0	280	9.4	18

# TRAVEL MOTOR (MST-600)

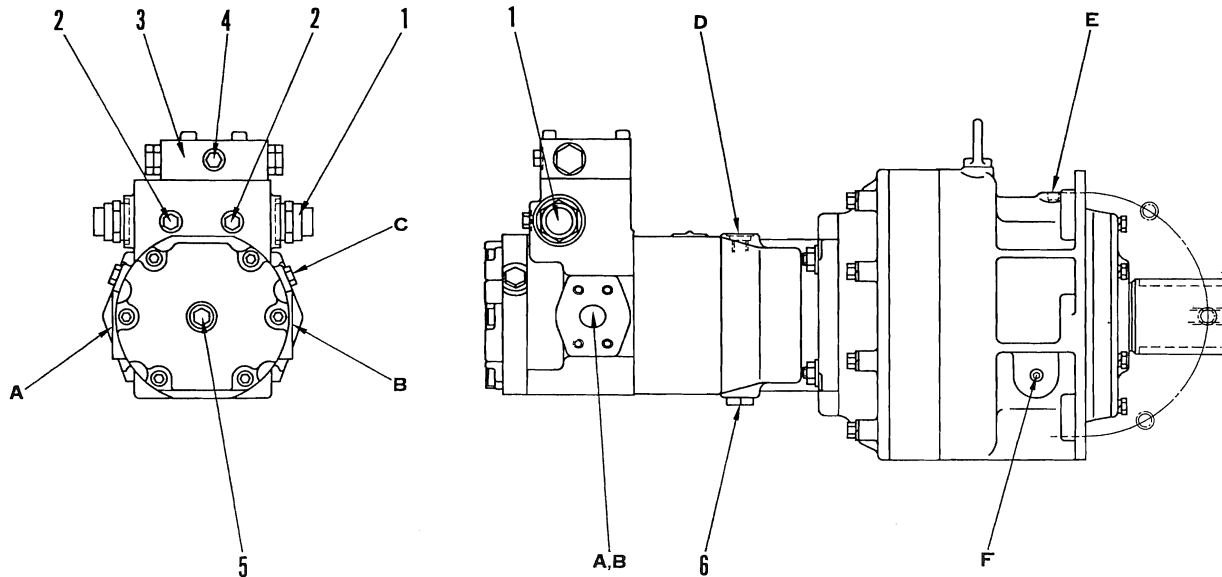

- 1. High-pressure relief valve
- 2. Plug for high-pressure (7/16-20UNF)
- 3. Flushing valve
- 4. Plug for charging pressure (7/16-20UNF)
- 5. Plug for disengaged parking brake
- 6. Drain plug
  
- A. From port B1 or B2 of main pump (Forward)
- B. From port A1 of A2 of main pump (Reverse)
- C. Port for parking brake
- D. Drain port
- E. Plug for oil supply (3/4-16UNF)
- F. Plug for oil check (PT1/8)

## GENERAL

- The travel motors are mounted in the right and left front of the main frame. They drive the sprocket to run or turn the vehicle.  
Swash plate-type travel motors are adopted.  
A parking disc brake and a planetary reduction gear are mounted.
- The table below shows the travel motor's discharge and high-pressure relief pressure.

Model	Motor discharge (cc/rev)	Relief pressure (kg/cm <sup>2</sup> )	Max. output speed (rpm)	Brake pressure (kg/cm <sup>2</sup> )
MT-600	51.6	315	130	9.5

- ★ The pressure at high pressure relief is 7 times the total of the last two digits on the model name plate stuck to the motor.

# TRAVEL MOTOR (MST-700 — 2000)

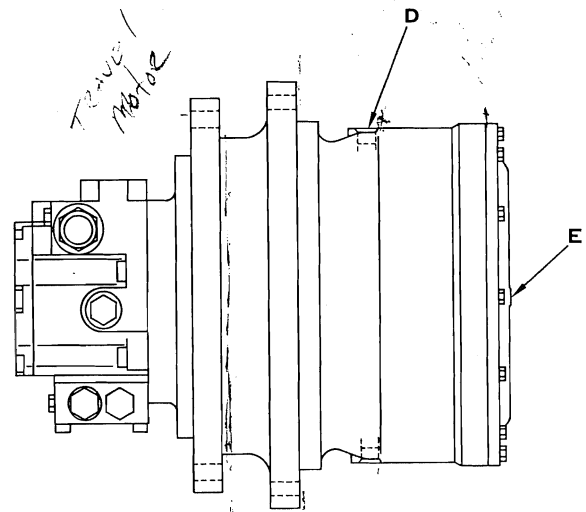
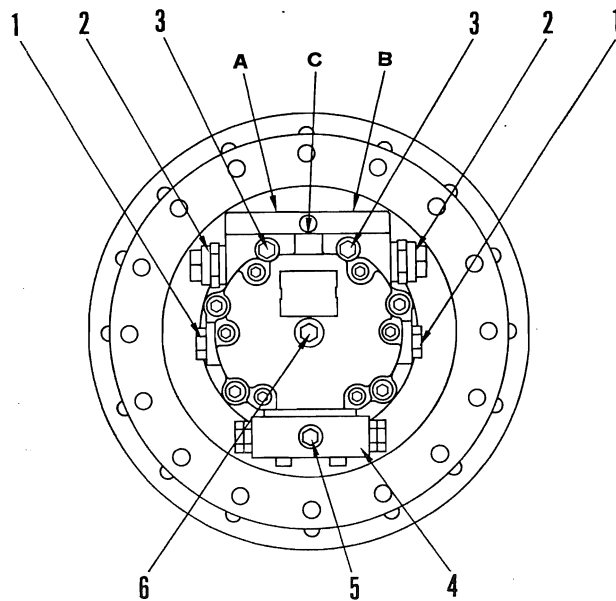

1. Drain plug
  2. High-pressure relief valve
  3. Plug for high-pressure (7/16-20UNF)
  4. Flushing valve
  5. Plug for charging pressure (7/16-20UNF)
  6. Plug for disengaged parking brake
- A. From port B1 or B2 of main pump (Reverse)
  - B. From port A1 or A2 of main pump (Forward)
  - C. Port for parking-brake
  - D. Plug for oil supply (3/4-16UNF)
  - E. Plug for oil check (PT1/8)

## GENERAL

- The travel motors are mounted in the right and left front of the main frame. They drive the sprocket to run or turn the vehicle. Swash plate-type travel motors are adopted. A parking disc brake and a planetary reduction gear are mounted.
- The table below shows the travel motor's discharge and high-pressure relief pressure.

Model	Motor discharge (cc/rev)	Relief pressure (kg/cm <sup>2</sup> )	Max. output speed (rpm)	brake pressure (kg/cm <sup>2</sup> )
MST-700	51.6	350	40.0	9.0
MST-800	51.6	350	40.0	9.0
MST-1100	69.8	385	54.9	9.0
MST-1500 (15001—15164)	69.8	385	54.9	9.0
MST-1500 (15165 and up)	69.8	350	54.9	9.0
MST-2000 (K20101—20128) (M02101—02104)	89.0	385	54.9	9.0
MST-2000 (K20129 and up) (M02105 and up)	89.0	350	54.9	9.0

★ Stamped mark: A figure indicating the pressure is stamped on the head of the plug of the high pressure relief valve.

(Example: 50, 55 (if the stamped mark is "50," the pressure is 7 times this value, so it is 350 kg/cm<sup>2</sup>; if the stamped mark is "55," the pressure is 7 times this, so it is 385 kg/cm<sup>2</sup>.)

# DETAIL DRAWING OF TRAVEL MOTOR

★ The diagram shows the MST-700, 800, 1100, 1500 and 2000.

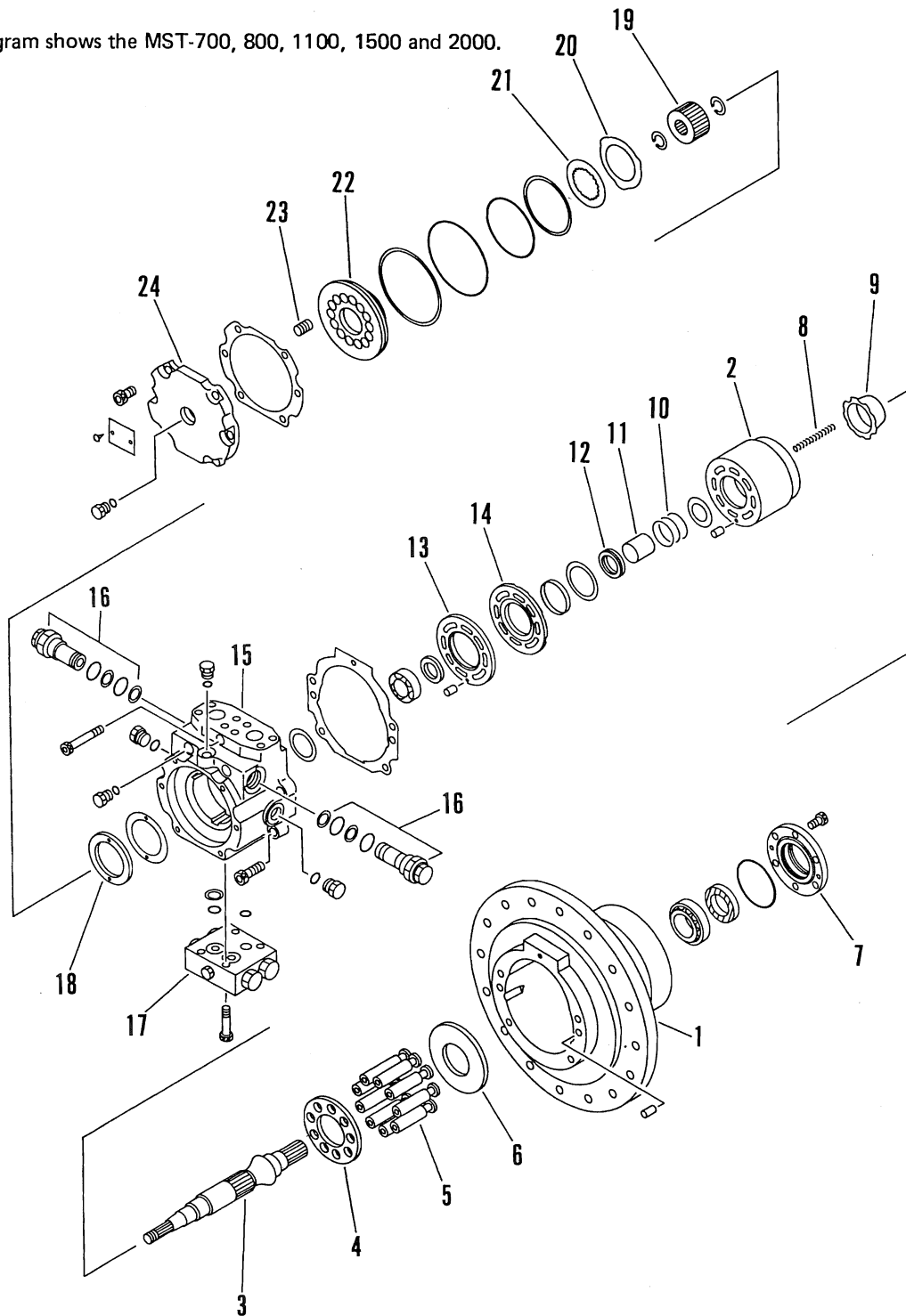

- |                   |               |                                |                   |
|-------------------|---------------|--------------------------------|-------------------|
| 1. Housing        | 7. Seal cover | 13. Swash plate                | 19. Brake hub     |
| 2. Cylinder block | 8. Spring     | 14. Bearing plate              | 20. Brake plate   |
| 3. Output shaft   | 9. Guide      | 15. End cap                    | 21. Brake disc    |
| 4. Retainer       | 10. Spring    | 16. High-pressure relief valve | 22. Brake piston  |
| 5. Piston         | 11. Guide     | 17. Flushing valve             | 23. Return spring |
| 6. Thrust plate   | 12. Retainer  | 18. Stopper                    | 24. Brake cover   |

## DETAIL DRAWING OF FLUSHING VALVE

★ The diagram shows the MST-700, 800, 1100, 1500 and 2000.

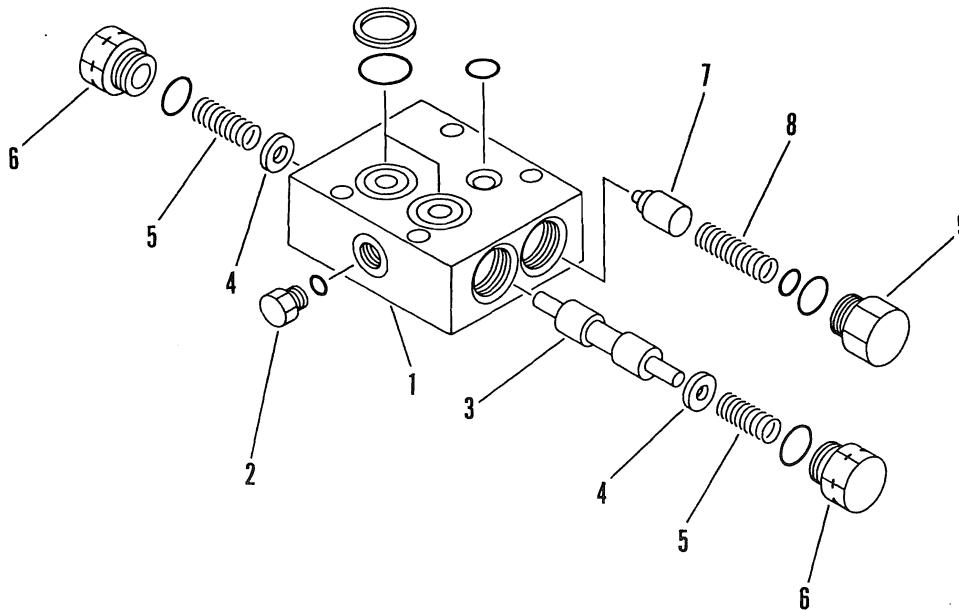

1. Valve housing
2. Plug for charging pressure
3. Shuttle valve spool
4. Retainer
5. Valve spring
6. Plug
7. Charging relief valve poppet
8. Poppet spring
9. Plug

### GENERAL

- A flushing valve is mounted in the lower part of each motor. It consists of 2 sets of shuttle and charge relief valves having different functions.

The shuttle valve is actuated by oil at the port which became the motor's suction side (high-pressure side). It sends the oil at the port which became the discharge side (low-pressure side) to the charge relief valve inlet.

The charge relief valve release oil to the oil cooler circuit when the low-pressure oil from the shuttle valve is pressurized above the specified pressure of 13 – 14 kg/cm<sup>2</sup>.

# TRAVEL MOTOR (MST-2500)

MST-2500 Serial No. 25134 – 25186

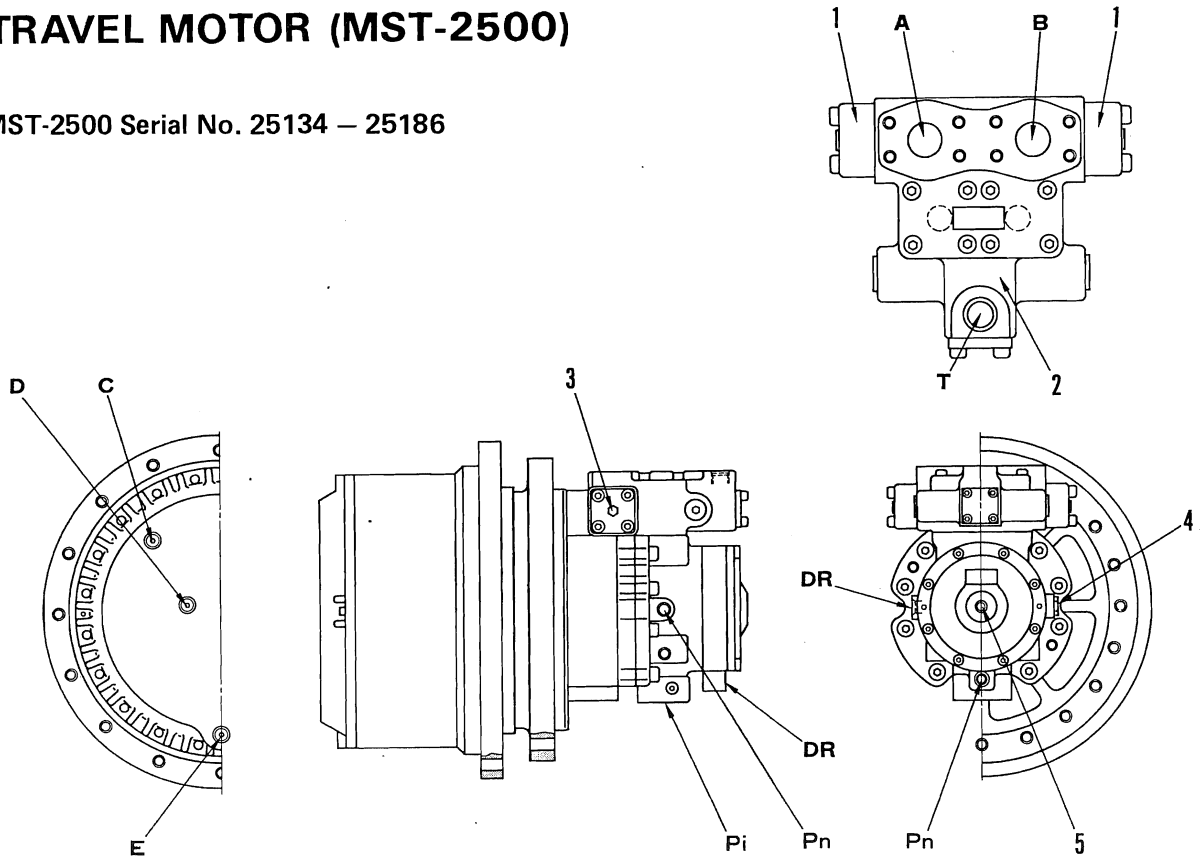

- 1. High-pressure relief valve
- 2. Flushing valve
- 3. Plug for high-pressure
- 4. Drain plug
- 5. Plug for disengaged parking brake
  
- A. From port B1 or B2 of main pump
- B. From port A1 or A2 of main pump
- Pn. From parking brake valve
- Pi. From H-L speed changing solenoid valve
- DR. To hydraulic tank
- T. To oil cooler
- C. Plug for oil supply (PT 1/2)
- D. Plug for oil check (PT 1/2)
- E. Plug for oil drain (PT 1/2)

## GENERAL

- The travel motors are mounted in the right and left front of the main frame. They drive the sprocket to run or turn the vehicle.

Swash plate-type travel motors are adopted.

A parking disc brake and a planetary reduction gear are mounted.

There is a high/low speed selector mechanism installed to the travel motor. This is actuated by the high/low speed selector switch in the operator's compartment, and provides two-stage selection of the swash plate angle to allow selection of a travel speed to match the load of the operation.

The high/low speed selector mechanism consists of the high/low speed selector valve and cylinder that switches the swash plate inside the travel motor, the high/low speed solenoid selector valve outside the travel motor that sends the pilot pressure to the high/low speed selector valve, and the switch in the operator's compartment.

The pressure of the pilot circuit is set to 25 kg/cm<sup>2</sup> by the charge relief valve at the rear of the operator's compartment.

- The table below shows the travel motor's discharge and high-pressure relief pressure.

Model	Motor discharge (cc/rev)	Relief pressure (kg/cm <sup>2</sup> )	Max. output speed (rpm)	H-L changing pressure (kg/cm <sup>2</sup> )	Brake pressure (kg/cm <sup>2</sup> )
MST-2500	172/123	350	54/75	15.0	13.1

# TRAVEL MOTOR (MST-2200, 2500)

MST-2200 Serial No. 22001 –  
 MST-2500 Serial No. 25187 –

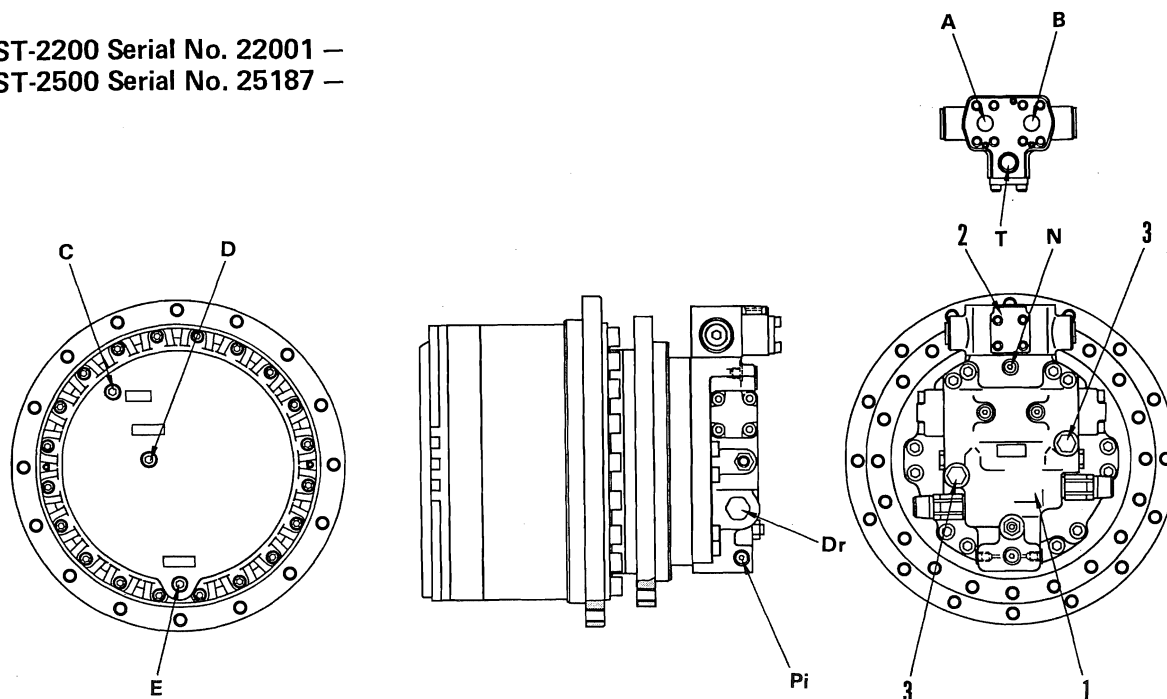

- 1. High-pressure relief valve
- 2. Flushing valve
- 3. Plug for disengaged parking brake
  
- A. From port B1 or B2 of main pump
- B. From port A1 of A2 of main pump
- N. From parking brake valve
- Pi. From H-L speed changing solenoid valve
- DR. To hydraulic tank
- T. To oil cooler
- C. Plug for oil supply (PT 1/2)
- D. Plug for oil check (PT 1/2)
- E. Plug for oil drain (PT 1/2)

## GENERAL

- The travel motors are mounted in the right and left front of the main frame. They drive the sprocket to run or turn the vehicle. Swash plate-type travel motors are adopted. A parking disc brake and a planetary reduction gear are mounted. There is a high/low speed selector mechanism installed to the travel motor. This is actuated by the high/low speed selector switch in the operator's compartment, and provides two-stage selection of the swash plate angle to allow selection of a travel speed to match the load of the operation. The high/low speed selector mechanism consists of the high/low speed selector valve and cylinder that switches the swash plate inside the travel motor, the high/low speed solenoid selector valve outside the travel motor that sends the pilot pressure to the high/low speed selector valve, and the switch in the operator's compartment. The pressure of the pilot circuit is set to 25 kg/cm<sup>2</sup> by the charge relief valve at the rear of the operator's compartment.
- The table below shows the travel motor's discharge and high-pressure relief pressure.

Model	Motor discharge (cc/rev)	Relief pressure (kg/cm <sup>2</sup> )	Max. output speed (rpm)	H-L changing pressure (kg/cm <sup>2</sup> )	Brake pressure (kg/cm <sup>2</sup> )
MST-2200	172/105	350	58/94	15.0	13.1
MST-2500	172/123	350	54/75	15.0	13.1



# TRAVEL MOTOR SPEED CHANGING CIRCUIT (MST-2200, 2500)

## OUTLINE

- The high/low speed selector circuit of the travel motor consists of the high/low speed selector valve (built into the travel motor) and piston cylinder that switches the swash plate angle of the travel motor, the high/low speed solenoid selector valve installed on top of the travel motor that sends the pilot pressure to the high/low speed selector valve, and the switch inside the operator's compartment. The pressurized oil in the circuit is supplied from the main pump charge circuit.

## OIL FLOW

- The pressurized oil for the travel motor high/low speed selector circuit is supplied from the main pump charge circuit, so the explanation will start from the flow of the oil in the main pump charge circuit. The pressurized oil in the parking brake circuit is also supplied from the main pump charge circuit.
- The oil in the hydraulic tank is sucked up by the charge pump, passes through main control valve (1), and hose (2), and then enters hydraulic line filter (3) at the rear of the operator's cab. The oil is cleaned by the line filter, then passes through hose (4) and enters main pump charge relief valve (5). After being set to 20 kg/cm<sup>2</sup>, it passes through hoses (6) and (7), and flows to the charge port of main pump (8). Hose (9) takes the oil relieved by the charge relief valve through the oil cooler back to the hydraulic tank. This explains the flow of the oil in the main pump charge circuit. Hose (17) connected to the inlet port of hydraulic line filter (3) takes oil to the parking brake valve installed in the operator's cab, and when the parking brake lever is set to the TRAVEL position, the oil is then sent to the brake port of the travel motor from hose (17) to release the parking brake. In other words, hose (17) sends pressurized oil to the parking brake circuit.

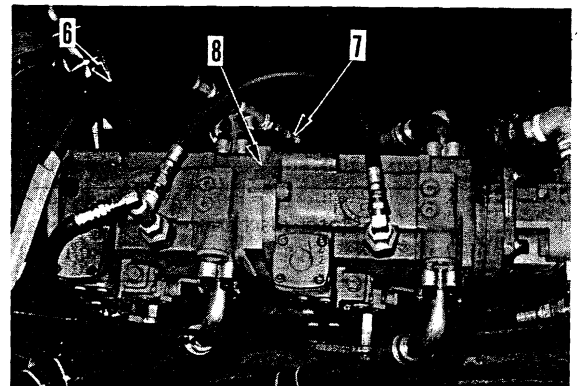
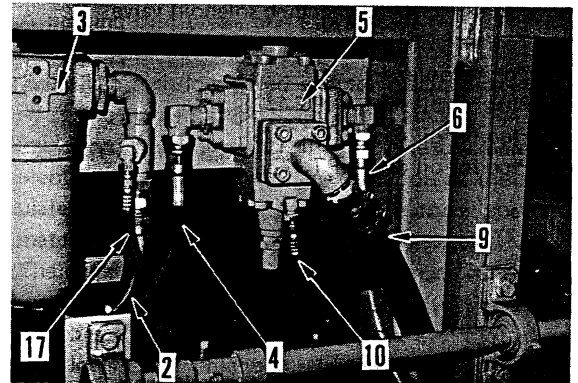
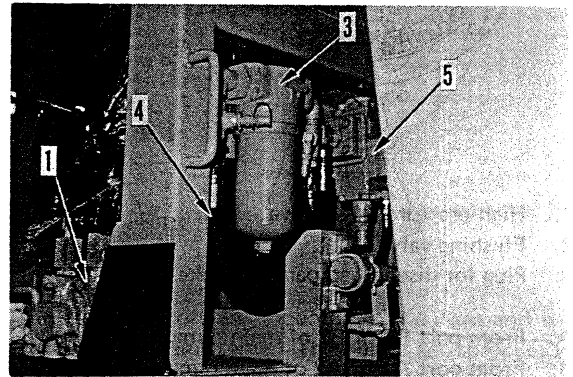

- The high-low speed selector circuit of the travel motor takes its hydraulic power from the oil coming from hose (10) connected to main pump charge relief valve (5).

- The oil passing through hose (10) flows to high-low speed solenoid selector valve (11) on top of the left travel motor.

The flow of the oil is switched according to the operation of high-low speed selector switch (15) in the operator's compartment.

If the high-low speed selector switch is at the low position, the solenoid selector valve is not actuated, and the high pressure oil passing through hose (10) does not flow beyond the solenoid selector valve.

At the same time, the pilot pressure bearing on the travel motor passes through hose (12) and returns to the solenoid selector valve. It is then returned to the hydraulic tank and the travel motor is set in the low speed condition. If the high-low speed selector switch is set to the high position, the solenoid selector valve is actuated, and the high pressure oil passing through hose (10) goes out from hose (12) and is divided to the left and right. It passes through hose (13) and becomes the pilot pressure for the high-low speed selector valve inside travel motor (14), switches the valve, and sets the travel motor to the high speed condition.

In other words, the high-low speed solenoid selector valve switches the pilot pressure operating the high-low speed selector valve built into the travel motor. The high-low speed selector valve switches the high pressure oil from the main pump and sends it to the piston cylinder that operates the swash plate angle of the travel motor.

When the high-low speed selector switch is at the high position, the above actuation is carried out. At the same time, high speed indicator lamp (16) beside the switch lights up to inform the operator that the machine is in the high speed condition.

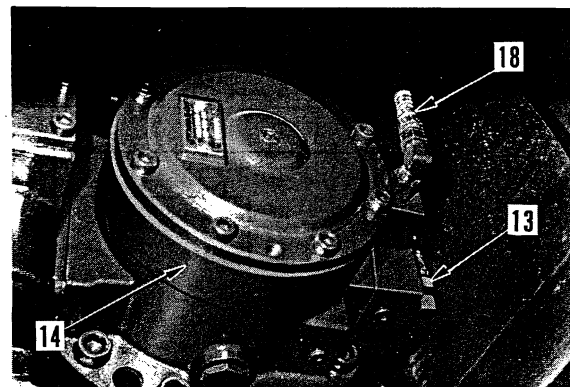
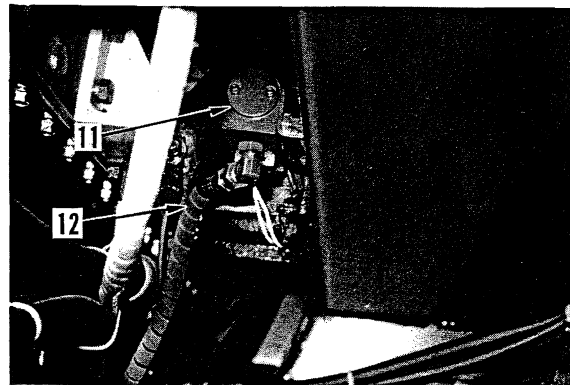
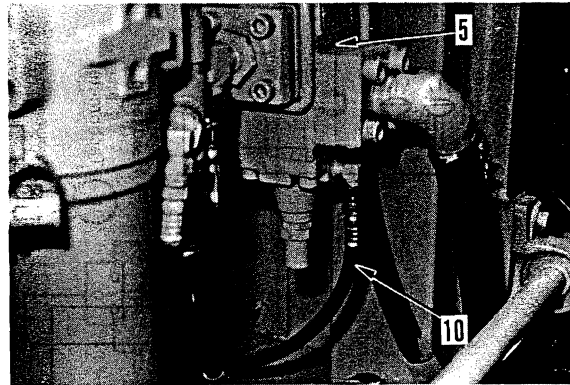

# ELECTRICAL CIRCUIT DIAGRAM (MST-500, 700, 1100, 2000)

MST-500 Serial No. 50133 —  
 MST-700 Serial No. 70279 — 70767  
 MST-1100 Serial No. 11272 — 11789  
 MST-2000 Serial No. 20160 —  
 MST-2000 Serial No. 20160 — 20488

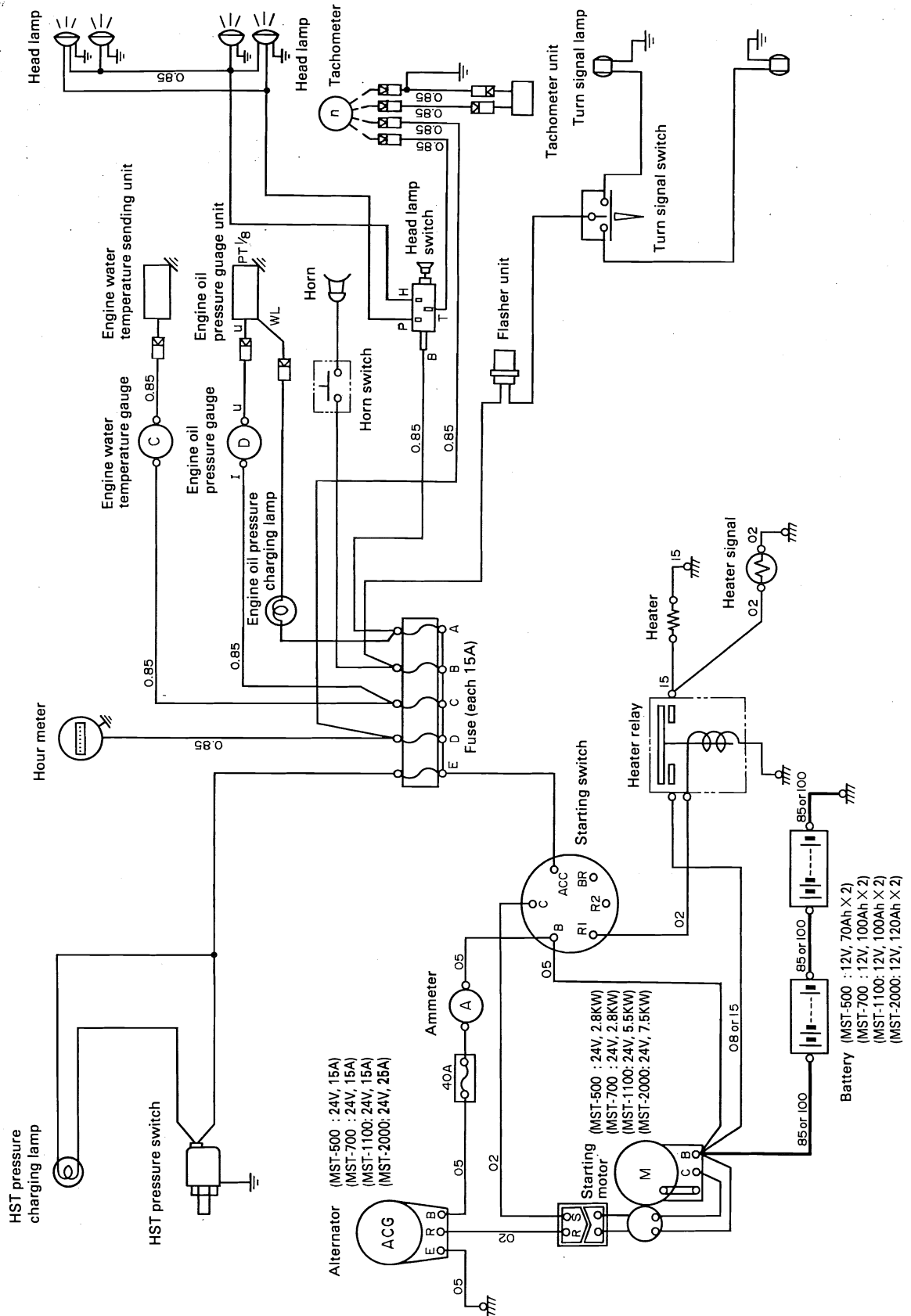

# ELECTRICAL CIRCUIT DIAGRAM (MST-500, 700, 1100, 2000)

MST-700 Serial No. 70768 -  
 MST-1100 Serial No. 11790 -  
 MST-2000 Serial No. 20489 -

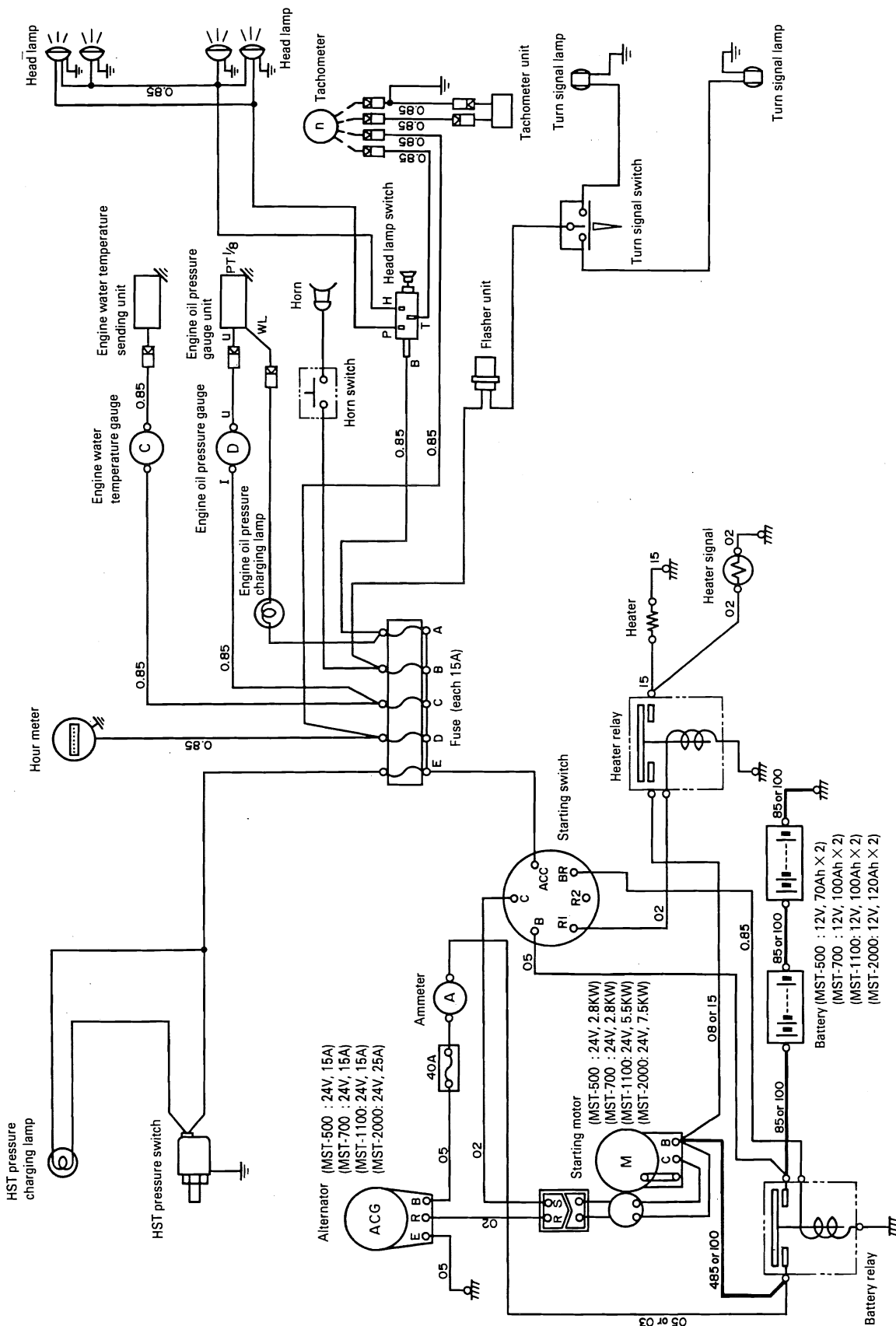

# ELECTRICAL CIRCUIT DIAGRAM (MST-600, 800, 1500, 2500)

MST-600 Serial No. 1995 - 2700  
 MST-800 Serial No. 1347 - 2400  
 MST-1500 Serial No. 15061 -  
 MST-2500 Serial No. 25134 -

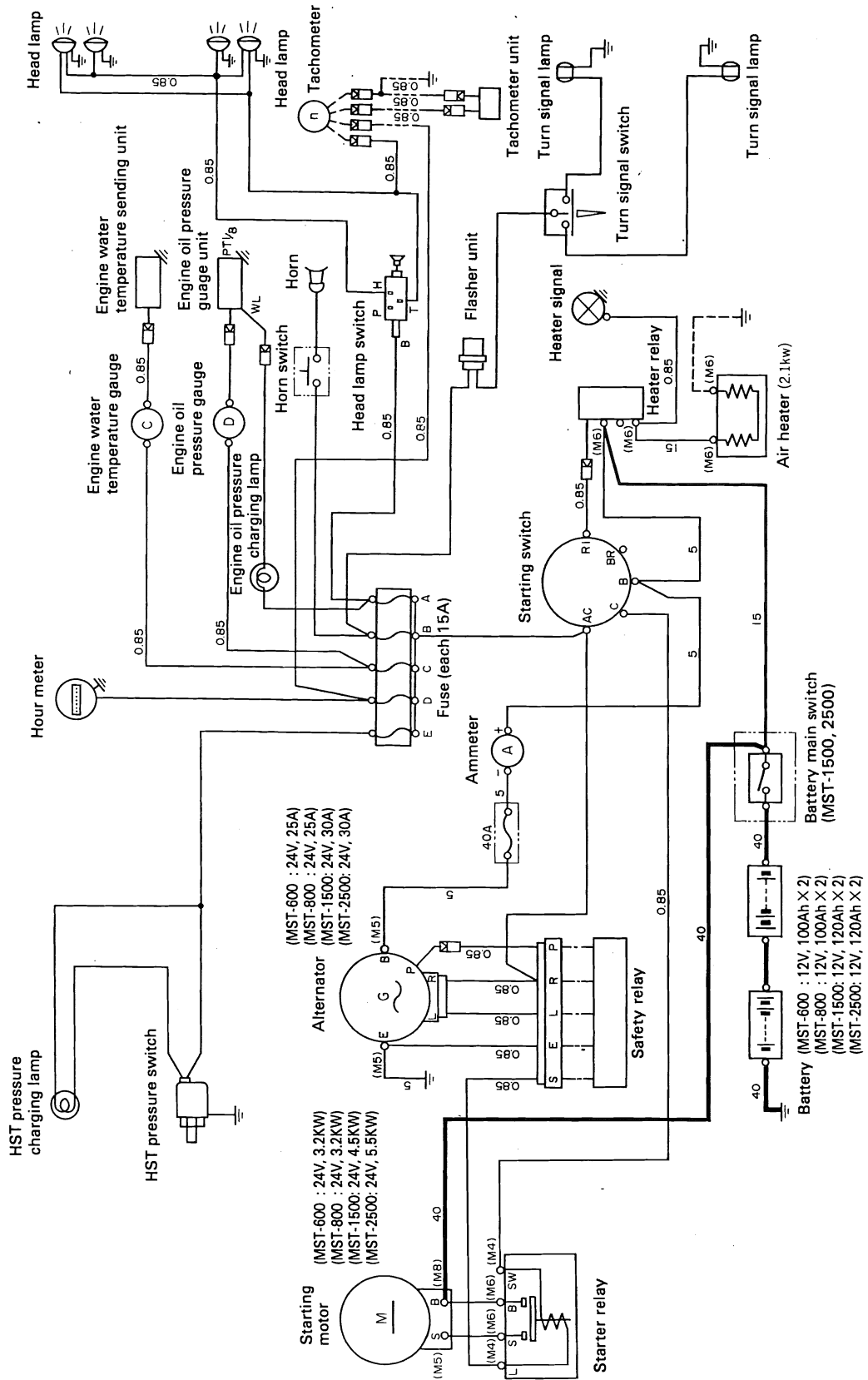

# ELECTRICAL CIRCUIT DIAGRAM

MST-600 Serial No. 2701 -  
MST-800 Serial No. 2401 -

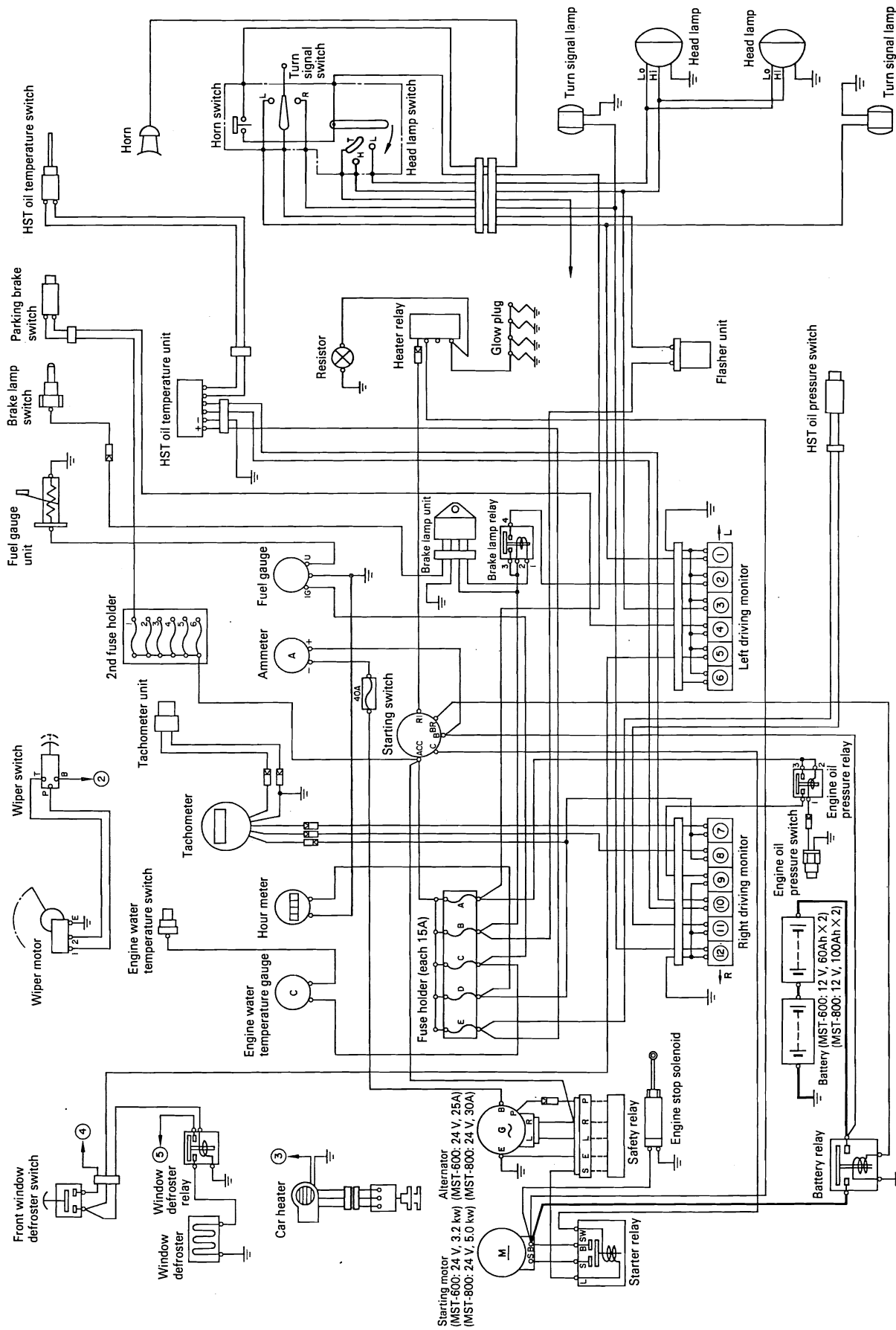

# ELECTRICAL CIRCUIT DIAGRAM (MST-2200)

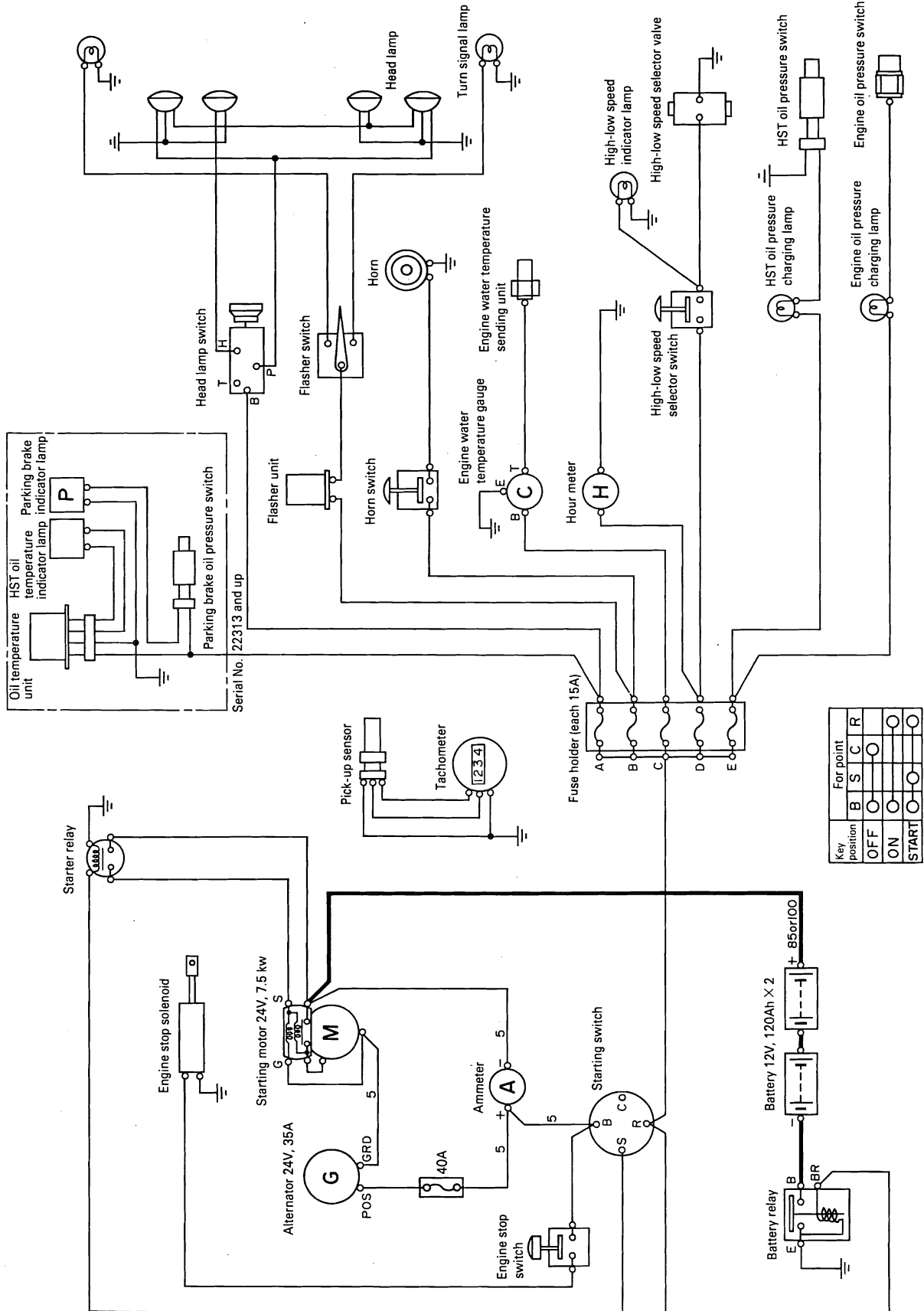

Key position	For point		
	B	S	C
OFF	○	○	○
ON	○	○	○
START	○	○	○

---

## 20 TESTING AND ADJUSTING

---

Standards of testing and adjusting .....	20- 2
Adjusting rubber crawler .....	20- 7
Measuring hydraulic pressure .....	20- 8
Checking main pump parts .....	20-16
Checking travel motor parts .....	20-22
Test run of HST .....	20-23
How to release parking brake .....	20-24



# STANDARDS OF TESTING AND ADJUSTING

## MST-500

Category	Check item	Measuring conditions	Unit	Standard value for new car	Judgement criteria
H S T	Main pump charging pressure	• At engine high idling	kg/cm <sup>2</sup>	20	
	Travel motor relief pressure	• Vehicle fixing device used • Vehicle running, turning condition		280	
	Traveling speed	• Time required for traveling 20 m after approach run of at least 10 m on flat ground	seconds	6.5 ± 0.5	
Work equipment	Control valve main relief pressure	• Cylinder stroke end	kg/cm <sup>2</sup>	175	
	Dump body operating speed	• Rated engine speed • No load	Raise	4.5	
			Down	4.5	
Natural fall of dump body	• Amount of fall from max. raise position of dump body after 5 minutes	mm	20		

## MST-600

Category	Check item	Measuring conditions	Unit	Standard value for new car	Judgement criteria
H S T	Main pump charging pressure	• At engine low idling	kg/cm <sup>2</sup>	13 – 14	
		• At engine high idling		16 – 18	
	Travel motor relief pressure	• Vehicle fixing device used • Vehicle running, turning condition		315	
	Travel motor charging pressure	• Vehicle running, turning condition		12 – 13	
	Traveling speed	• Time required for traveling 20 m after approach run of at least 10 m on flat ground		seconds	6.0 ± 0.5
Work equipment	Control valve main relief pressure	• Cylinder stroke end	kg/cm <sup>2</sup>	175	
	Dump body operating speed	• Rated engine speed • No load	Raise	4.5	
			Down	4.5	
Natural fall of dump body	• Amount of fall from max. raise position of dump body after 5 minutes	mm	20		

### MST-700

Category	Check item	Measuring conditions	Unit	Standard value for new car	Judgement criteria
H S T	Main pump charging pressure	• At engine low idling	kg/cm <sup>2</sup>	13 – 14	
		• At engine high idling		16 – 18	
	Travel motor relief pressure	• Vehicle fixing device used • Vehicle running, turning condition		350	
	Travel motor charging pressure	• Vehicle running, turning condition		12 – 13	
	Traveling speed	• Time required for traveling 20 m after approach run of at least 10 m on flat ground		seconds	6.0 ± 0.5
Work equipment	Control valve main relief pressure	• Cylinder stroke end	kg/cm <sup>2</sup>	175	
	Dump body operating speed	• Rated engine speed • No load	Raise	9.0	
			Down	12.0	
Natural fall of dump body	• Amount of fall from max. raise position of dump body after 5 minutes	mm	20		

### MST-800

Category	Check item	Measuring conditions	Unit	Standard value for new car	Judgement criteria
H S T	Main pump charging pressure	• At engine low idling	kg/cm <sup>2</sup>	13 – 14	
		• At engine high idling		16 – 18	
	Travel motor relief pressure	• Vehicle fixing device used • Vehicle running, turning condition		350	
	Travel motor charging pressure	• Vehicle running, turning condition		12 – 13	
	Traveling speed	• Time required for traveling 20 m after approach run of at least 10 m on flat ground		seconds	6.0 ± 0.5
Work equipment	Control valve main relief pressure	• Cylinder stroke end	kg/cm <sup>2</sup>	165	
	Dump body operating speed	• Rated engine speed • No load	Raise	9.0	
			Down	10.0	
Natural fall of dump body	• Amount of fall from max. raise position of dump body after 5 minutes	mm	20		

MST-1100

Category	Check item	Measuring conditions	Unit	Standard value for new car	Judgement criteria
H S T	Main pump charging pressure	• At engine low idling	kg/cm <sup>2</sup>	13 – 14	
		• At engine high idling		16 – 18	
	Travel motor relief pressure	• Vehicle fixing device used • Vehicle running, turning condition		385	
	Travel motor charging pressure	• Vehicle running, turning condition		12 – 13	
	Traveling speed	• Time required for traveling 20 m after approach run of at least 10 m on flat ground		seconds	7.8 ± 0.5
Work equipment	Control valve main relief pressure	• Cylinder stroke end	kg/cm <sup>2</sup>	165	
	Dump operating speed	• Rated engine speed • No load	Raise	13.0	
			Down	14.5	
Natural fall of dump body	• Amount of fall from max. raise position of dump body after 5 minutes	mm	20		

MST-1500

Category	Check item	Measuring conditions	Unit	Standard value for new car	Judgement criteria
H S T	Main pump charging pressure	• At engine low idling	kg/cm <sup>2</sup>	13 – 14	
		• At engine high idling		16 – 18	
	Travel motor relief pressure	• Vehicle fixing device used • Vehicle running, turning condition		385 (#15001 –15164) 350 (#15165– )	
	Pressure overdrive valve switching pressure	• Vehicle fixing device used • Vehicle running condition		370 (#15094 –15164) 350 (#15165– )	
	Travel motor charging pressure	• Vehicle running, turning condition		12 – 13	
	Traveling speed	• Time required for traveling 20 m after approach run of at least 10 m on flat ground		seconds	6.0 ± 0.5
Work equipment	Control valve main relief pressure	• Cylinder stroke end	kg/cm <sup>2</sup>	165	
	Dump operating speed	• Rated engine speed • No load	Raise	15.0	
			Down	10.5	
Natural fall of dump body	• Amount of fall from max. raise position of dump body after 5 minutes	mm	20		

### MST-2000

Category	Check item	Measuring conditions	Unit	Standard value for new car	Judgement criteria
HST	Main pump charging pressure	• At engine low idling	kg/cm <sup>2</sup>	13 – 14	
		• At engine high idling		16 – 18	
	Travel motor relief pressure	• Vehicle fixing device used • Vehicle running, turning condition		385 (#M02101–M02104) (#K20101–K20128) 350 (#M02105–) (#K20129–)	
	Pressure overdrive valve switching pressure	• Vehicle fixing device used • Vehicle running condition		370 (#M02101–M02104) (#K20101–K20128) 350 (#M02105–) (#K20129–)	
	Travel motor charging pressure	• Vehicle running, turning condition		12 – 13	
	Traveling speed	• Time required for traveling 20 m after approach run of at least 10 m on flat ground		seconds	7.2 ± 0.5
Work equipment	Control valve main relief pressure	• Cylinder stroke end	kg/cm <sup>2</sup>	165	
	Dump operating speed	• Rated engine speed • No load	Raise	18.0	
			Down	12.0	
Natural fall of dump body	• Amount of fall from max. raise position of dump body after 5 minutes	mm	20		

### MST-2200

Category	Check item	Measuring conditions	Unit	Standard value for new car	Judgement criteria
HST	Main pump charging pressure	• At engine 1000 rpm	kg/cm <sup>2</sup>	25	
	Travel motor relief pressure	• Vehicle fixing device used • Vehicle running, turning condition		325	
	Travel motor charging pressure	• Vehicle running, turning condition		16 – 18	
	Traveling speed	• Time required for traveling 20 m after approach run of at least 10 m on flat ground		seconds	6.3 ± 0.5
Work equipment	Control valve main relief pressure	• Cylinder stroke end	kg/cm <sup>2</sup>	165	
	Dump operating speed	• Rated engine speed • No load	Raise	12.5	
			Down	13.0	
Natural fall of dump body	• Amount of fall from max. raise position of dump body after 5 minutes	mm	20		

**MST-2500**

Category	Check item	Measuring conditions	Unit	Standard value for new car	Judgement criteria
HST	Main pump charging pressure	• At engine 1000 rpm	kg/cm <sup>2</sup>	25	
	Travel motor relief pressure	• Vehicle fixing device used • Vehicle running, turning condition		350	
	Travel motor charging pressure	• Vehicle running, turning condition		16 – 18	
	Traveling speed	• Time required for traveling 20 m after approach run of at least 10 m on flat ground	seconds	6.3 ± 0.5	
Work equipment	Control valve main relief pressure	• Cylinder stroke end	kg/cm <sup>2</sup>	165	
	Dump operating speed	• Rated engine speed • No load	Raise	15.5	
			Down	11.0	
	Natural fall of dump body	• Amount of fall from max. raise position of dump body after 5 minutes	mm	20	

# ADJUSTING RUBBER CRAWLER

● If the rubber crawler comes off or its tension must be adjusted, it should be remounted and adjusted as follows.

1. Apply jacks to the front and rear of the main frame and lift the relevant side. Then put a support under the frame.
  - ★ Confirm that the support is supporting the body securely.
2. Remove the cover (1) and loosen the lubricator (2) to purge the cylinder interior or grease.
  - ★ Never remove the lubricator.
3. Push in the idler holder (3) towards the body front.
4. Engage the rubber crawler first with the front sprocket and then with the idler in the rear part.
  - ★ Take sufficient care because the rubber crawler is very heavy.
5. Push in the rubber crawler while turning the sprocket.
6. Set steel pipes, etc., in the rubber crawler, and turn the sprocket gain.
  - ★ The sprocket must be turned in the direction shown in the diagram below.

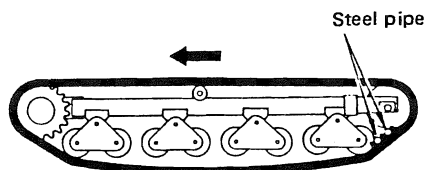

★ Check that the rubber crawler is securely engaged with the sprocket and the rear idler.

7. Tighten the lubricator (2), feed grease under pressure with a grease pump, and adjust dimension A from the rear end of the truck frame to the rear idler center to the standard value.
8. Install the grease cover (1).
9. Check that the rubber crawler is securely engaged with the sprocket and the rollers and that its tension is sufficient, and then lower the body.

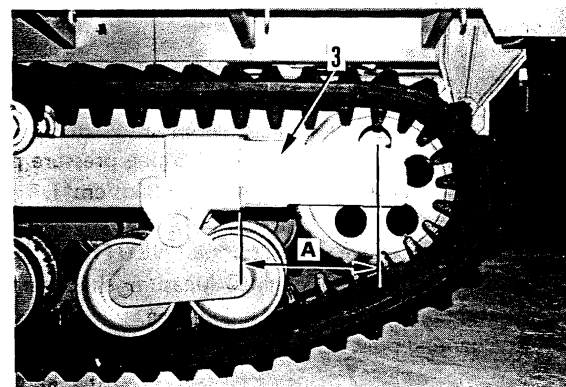
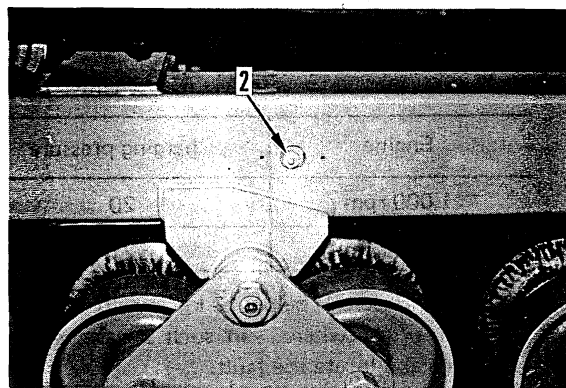
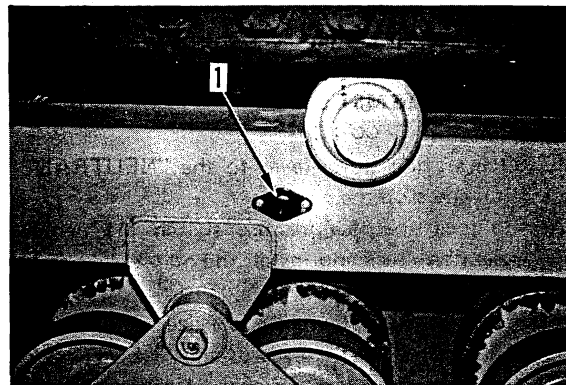

★ Dimension A

Unit: mm

Model	Standard value
MST-500	290 ± 5
MST-600	215 ± 5
MST-700	335 ± 5
MST-800	315 ± 5
MST-1100	305 ± 5

Unit: mm

Model	Standard value
MST-1500	440 ± 5 (Serial No. 15001 — 15150) 370 ± 5 (Serial No. 15151 and up)
MST-2000	470 ± 5
MST-2200	435 ± 5
MST-2500	600 ± 5 (Serial No. 25101 — 25106) 550 ± 5 (Serial No. 25107 and up)

# MEASURING HYDRAULIC PRESSURE

## MEASURING MAIN PUMP CHARGING PRESSURE

### ★ Applicable to MST-500

1. Operate the travel lever to the "NEUTRAL" position and stop the engine.
2. Remove the low-pressure switch (1) behind the operator's seat and install the oil pressure gauge (50 kg/cm<sup>2</sup>).

★ Low-pressure switch screw size: PT 1/4

3. Operate the travel lever to the "NEUTRAL" position and start the engine. Measure the charging pressure when the engine speed is 1,000 rpm and 2,000 rpm.

★ Charging pressure

Unit: kg/cm<sup>2</sup>

Engine	Charging pressure
1,000 rpm	20
2,000 rpm	21

★ If the pressure is below 10 kg/cm<sup>2</sup>, there may be a fault somewhere. In such a case, stop the engine and locate the fault.

### ★ Applicable to MST-600, 700, 800, 1100, 1500 and 2000

1. Operate the travel lever to the "NEUTRAL" position and stop the engine.
2. Remove the plug (1) of the charging pressure port and install the oil pressure gauge (50 kg/cm<sup>2</sup>).

★ Plug screw size: 7/16-20 UNF

3. Operate the travel lever to the "NEUTRAL" position and start the engine. Measure the charging pressure at low idling and high idling.

★ Charging pressure

Unit: kg/cm<sup>2</sup>

	Engine speed	Charging pressure
Unload	Low idling	13 - 14
	High idling	16 - 18
On load	Low idling	11 - 13
	High idling	14 - 16

★ If the pressure is below 10 kg/cm<sup>2</sup>, there may be a fault somewhere. In such a case, stop the engine and locate the fault.

### ★ For MST-500

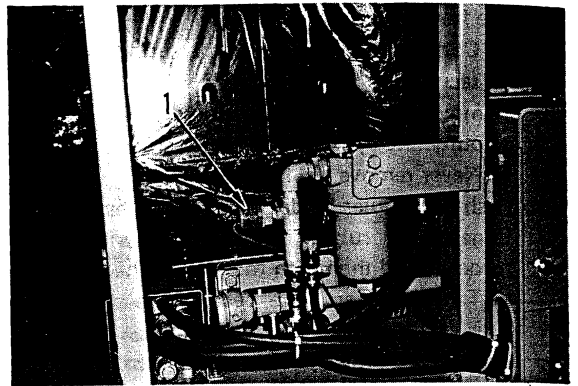

### ★ For MST-1100

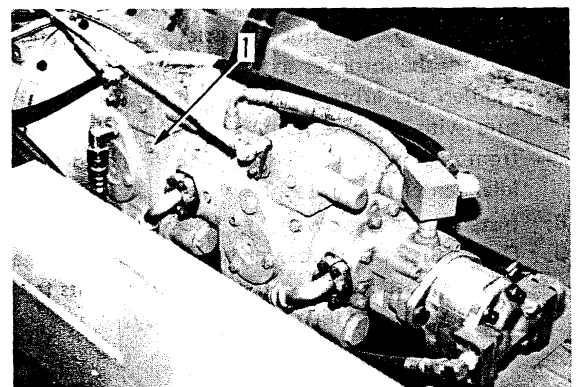

★ Applicable to MST-2200 and MST-2500

1. Operate the travel lever to the "NEUTRAL" position and stop the engine.
2. Remove the low-pressure switch (1) behind the operator's seat and install the oil pressure gauge (50 kg/cm<sup>2</sup>).

★ Low-pressure switch part: Quick coupler

3. Operate the travel lever to the "NEUTRAL" position and start the engine. Measure the charging pressure when the engine speed is 1,000 rpm.

★ Charging pressure

Unit: kg/cm<sup>2</sup>

Engine	Charging pressure
1,000 rpm	25

- ★ If the pressure is below 10 kg/cm<sup>2</sup>, there may be a fault somewhere. In such a case, stop the engine and locate the fault.
- ★ If the pressure of pump charge relief valve (2) does not reach 25 kg/cm<sup>2</sup>, remove cap (3) of the valve, loosen the locknut, and adjust the pressure with the adjustment screw.

★ For MST-2500

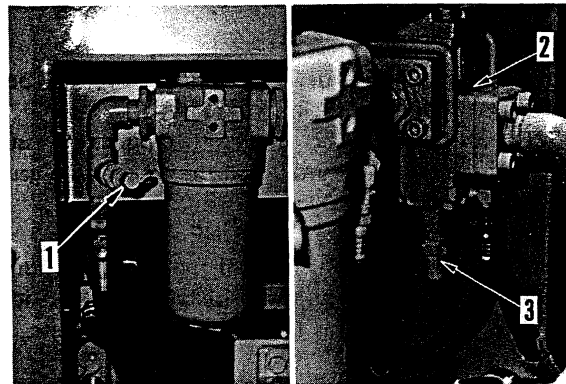



## MEASURING PRESSURE OVERRIDE SWITCHING PRESSURE

★ Applicable to MST-1500 Serial No. 15094 and up, and MST-2000

1. Operate the travel lever to the "NEUTRAL" position and stop the engine.
2. Remove the plug (2) of the main pump's pressure override valve (1) and install the oil pressure gauge (600 kg/cm<sup>2</sup> or 470 kg/cm<sup>2</sup>).  
★ Plug screw size: 7/16-20UNF
3. To prevent the vehicle from running away during the hydraulic pressure measurement, connect it to firm fixtures such as fixed concrete blocks, etc., by wire ropes.  
★ The fixtures must be strong enough to not break by the vehicle's tractive power. In addition, use rather big wire ropes.
4. Operate the travel lever to the "NEUTRAL" position and start the engine. Start the vehicle by operating the lever and measure the pressure when the vehicle enters the shoe slipping condition due to the fixtures.  
★ Pressure override switching pressure.

Unit: kg/cm<sup>2</sup>

Model	Switching pressure
MST-1500 (#15094 - 15164)	370
MST-1500 (#15165 and up)	350
MST-2000 (#M02101 - 02104) (#K20101 - 20128)	370
MST-2000 (#M02105 and up) (#K20129 and up)	350

- ★ If the pressure is below the standard value, there may be a fault somewhere. In such a case, stop the engine and locate the fault.
5. If there is no fault, adjust the pressure using the adjustment screw (3).  
To adjust, loosen the locknut (4) and screw in the adjustment screw (3).  
★ The pressure increases/decreases 70kg/cm<sup>2</sup> when the adjustment screw is turned one complete turn.

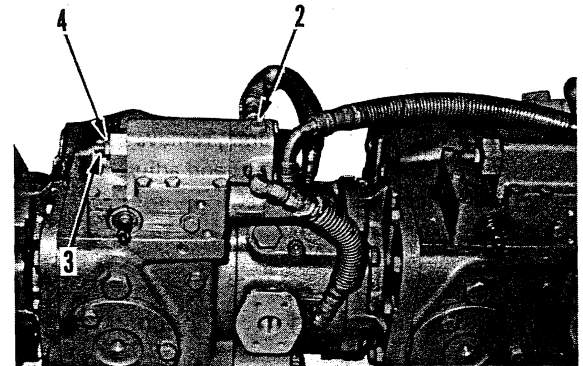
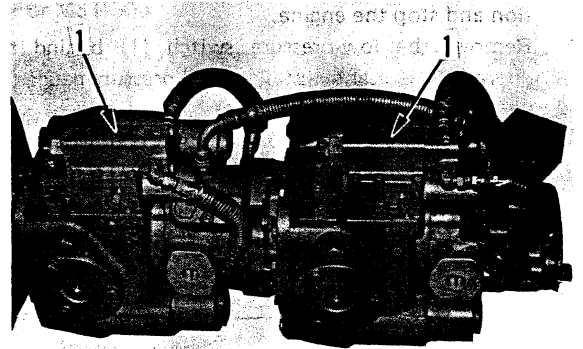

## MEASURING TRAVEL MOTOR RELIEF PRESSURE

★ Applicable to MST-500, 600, 700, 800, 1100 and MST-1500 Serial No. 15001 – 15093

1. Operate the travel lever to the "NEUTRAL" position and stop the engine.
2. Remove the plug (2) of the travel motor's high-pressure port and install the oil pressure gauge (600 kg/cm<sup>2</sup> or 470 kg/cm<sup>2</sup>).

★ Applicable to MST-600, 700, 800, 1100 and 1500.

Plug screw size: 7/16-20 UNF

★ The MST-500 doesn't have the pressure detection port mentioned above. Therefore, put an adaptor, etc., between the elbow (4) of the high-pressure hose connecting the main pump and the travel motor and the main pump and install the oil pressure gauge.

★ Main pump discharge port screw size: PT3/4

3. To prevent the vehicle from running away during the hydraulic pressure measurement, connect it to firm fixtures such as fixed concrete blocks, etc., by wire ropes.

★ The fixtures must be strong enough not to be broken by the vehicle's tractive power. In addition, use rather big wire ropes.

4. Operate the travel lever to the "NEUTRAL" position and start the engine. Start the vehicle by operating the lever and measure the pressure when the vehicle enters the shoe slipping condition due to the fixtures.

★ Relief pressure

Unit: kg/cm<sup>2</sup>

Model	Relief pressure
MST-500	280
MST-600	315
MST-700	350
MST-800	350
MST-1100	385
MST-1500	385

★ If the pressure is below the standard value, there may be a fault somewhere. In such a case, stop the engine and locate the fault.

★ For MST-500

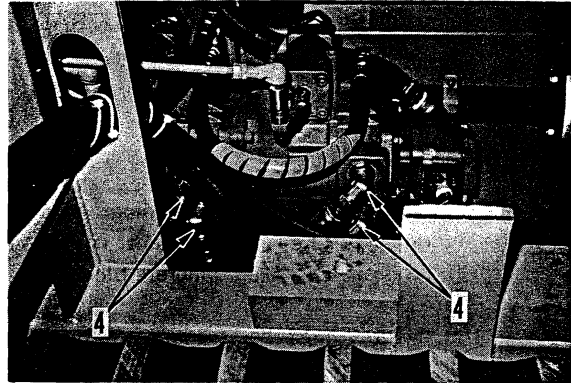

★ For MST-600

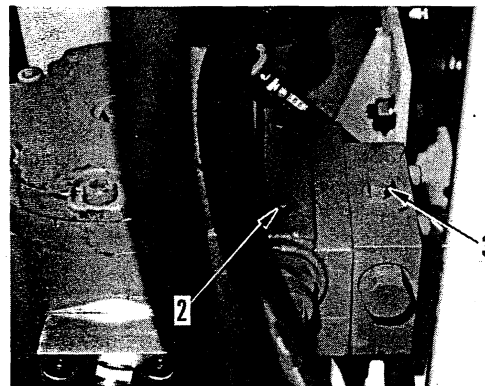

★ For MST-700, 800, 1100 and 1500



★ Applicable to MST-1500 Serial No. 15094 and up,  
and MST-2000

1. Operate the travel lever to the "NEUTRAL" position and stop the engine.
2. Remove the plug (2) of the travel motor's high-pressure port and install the oil pressure gauge (600 kg/cm<sup>2</sup> or 470 kg/cm<sup>2</sup>).

★ Plug screw size: 7/16-20 UNF

3. To prevent the vehicle from running away during the hydraulic pressure measurement, connect it to firm fixtures such as fixed concrete blocks, etc., by wire ropes.

★ The fixtures must be strong enough not to be broken by the vehicle's tractive power. In addition, use rather big wire ropes.

4. When measuring high-pressure, screw adjustment screw (1) of the pressure override valve to one turn. After adjusting high-pressure, return adjustment screw (1) and lock with locknut (4).

5. Operate the travel lever to the "NEUTRAL" position and start the engine. Start the vehicle by operating the lever and measure the pressure when the vehicle enters the shoe slipping condition due to the fixtures.

★ Relief pressure

Unit: kg/cm<sup>2</sup>

Model	Relief pressure
MST-1500	350
MST-2000 (# M02101 - 02104) (# K20101 - 20125)	385
MST-2000 (# M02105 and up) (# K20129 and up)	350

- ★ If the pressure is below the standard value, there may be a fault somewhere. In such a case, stop the engine and locate the fault.

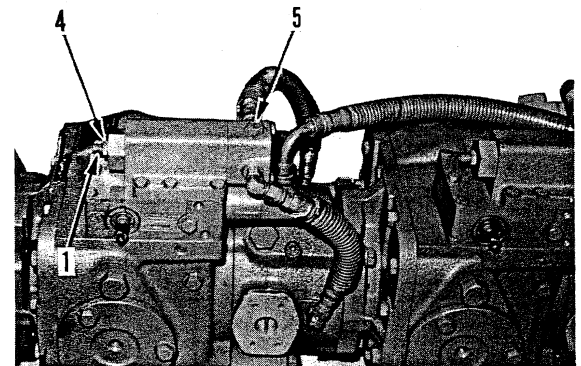
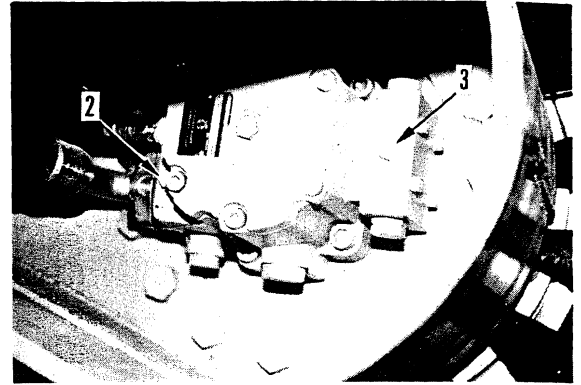

★ Applicable to MST-2200 and 2500

1. Operate the travel lever to the "NEUTRAL" position and stop the engine.
2. Remove the plug (2) of the travel motor's high-pressure port and install the oil pressure gauge (600 kg/cm<sup>2</sup> or 470 kg/cm<sup>2</sup>).

★ Applicable to MST-2500 Serial No. 25101 – 25186.

3. Remove the plug (2) of the main pump's high-pressure port and install the oil pressure gauge (600 kg/cm<sup>2</sup> or 470 kg/cm<sup>2</sup>).

★ Plug screw size: PF 1/4

★ Applicable to MST 2200 and MST-2500 Serial No. 25187 and up.

4. To prevent the vehicle from running away during the hydraulic pressure measurement, connect it to firm fixtures such as fixed concrete blocks, etc., by wire ropes.

★ The fixtures must be strong enough not to be broken by the vehicle's tractive power. In addition, use rather big wire ropes.

5. Operate the travel lever to the "NEUTRAL" position and start the engine. Start the vehicle by operating the lever and measure the pressure when the vehicle enters the shoe slipping condition due to the fixtures.

★ Relief pressure

Unit: kg/cm<sup>2</sup>

Model	Relief pressure
MST-2200	325
MST-2500	350

★ If the pressure is below the standard value, there may be a fault somewhere. In such a case, stop the engine and locate the fault.

★ For MST-2500 Serial No. 25101 – 25186

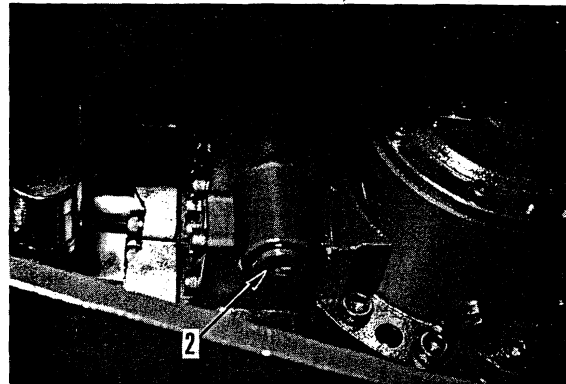

★ For MST-2200 and 2500 Serial No. 25187 –

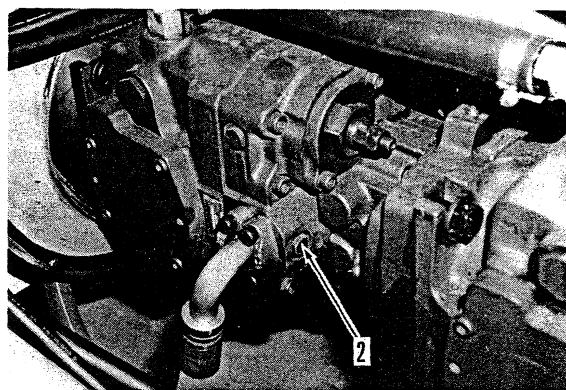

## MEASURING TRAVEL MOTOR CHARGING PRESSURE

★ Applicable to MST-600, 700, 800, 1100, 1500 and 2000

1. Operate the travel lever to the "NEUTRAL" position and stop the engine.
  2. Remove the plug (3) of the charging pressure port and install the oil pressure gauge (50 kg/cm<sup>2</sup>).
- ★ Plug screw size: 7/16-20UNF
3. Operate the travel lever to the "NEUTRAL" position and start the engine. Measure the charging pressure when the vehicle is started by operating the lever.

★ The charging pressure is common to the models.  
12 – 13 kg/cm<sup>2</sup>

★ If the pressure is below 10 kg/cm<sup>2</sup>, there may be a fault somewhere. In such a case, stop the engine and locate the fault.

★ For MST-600

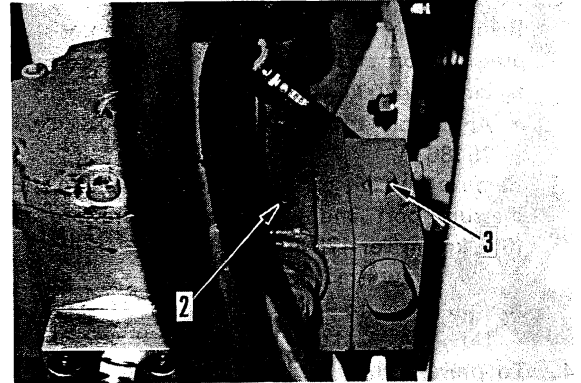

★ For MST-1100

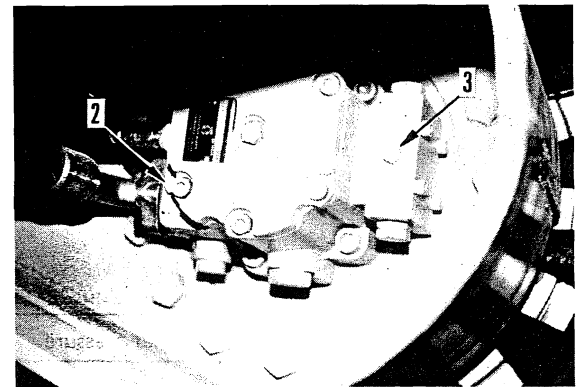

## MEASURING MAIN RELIEF PRESSURE OF DUMP CYLINDER CIRCUIT

★ Applicable to MST-500, 600 and 700

1. Operate the travel lever and dump lever to the "NEUTRAL" position and stop the engine.
2. Remove plug (1) of dump control valve and install the oil pressure gauge (470 kg/cm<sup>2</sup>).  
★ Plug screw size: PT 1/8
3. Operate the travel lever to the "NEUTRAL" position and start the engine. Raise the dump body by operating the dump lever and measure the pressure when the dump body (dump cylinder) is brought to the stroke end.

★ Main relief pressure

Unit: kg/cm<sup>2</sup>

Model	Main relief pressure
MST-500 - 700	175

★ For MST-500

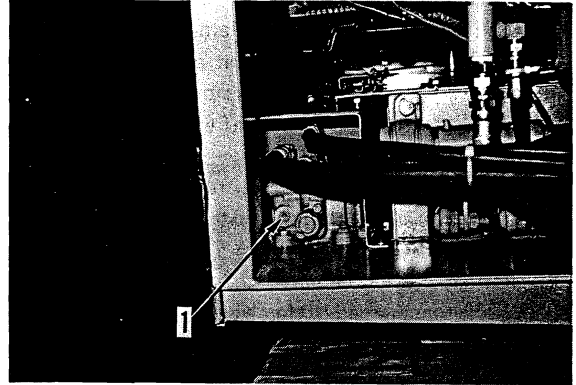

★ For MST-1500

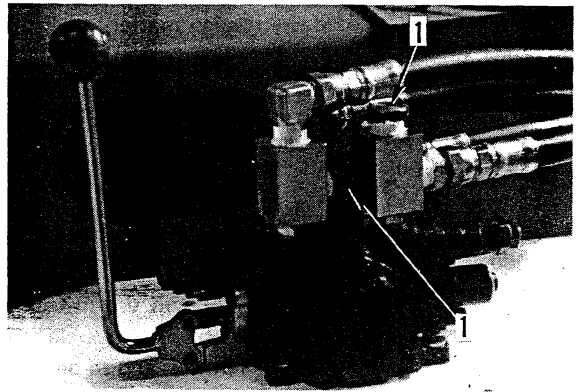

★ Applicable to MST-800, 1100, 1500, 2000, 2200 and 2500

1. Operate the travel lever and dump lever to the "NEUTRAL" position and stop the engine.
2. Remove plug (1) of the adapter on the dump control valve and install the oil pressure gauge (470 kg/cm<sup>2</sup>).  
★ Applicable to MST-800, 1100 and 1500.  
Plug screw size: PT 3/8  
★ Applicable to MST-2000, 2200 and 2500.  
Plug screw size: PT 1/2
3. Operate the travel lever to the "NEUTRAL" position and start the engine. Raise the dump body by operating the dump lever and measure the pressure when the dump body (dump cylinder) is brought to the stroke end.

★ Main relief pressure

Unit: kg/cm<sup>2</sup>

Model	Main relief pressure
MST-800 - 2500	165

# CHECKING MAIN PUMP PARTS

## CHECKING CHARGE RELIEF VALVE AND HIGH-PRESSURE RELIEF VALVE

★ Applicable to MST-500

- If the oil pressure warning lamp on the instrument panel lights up or in the event of such trouble as the vehicle does not move, lacks power, and so on, check the main pump's charge relief valve and high-pressure relief valve as follows.
  - The MST-500 high-pressure relief valve is mounted on the main pump unlike in other models.
1. Operate the travel lever to the "NEUTRAL" position and stop the engine.
  2. **Check the charge relief valve**  
Remove the charge relief valve (1) and check it for catching dust, foreign matter, etc., spring breakdown or dilation, the seat abrasion, etc.
  3. **Check the high-pressure relief valve**  
Remove the high-pressure relief valve (2) and check it for biting-in of dust, foreign matter, etc., spring breakdown or dilation, seat abrasion, etc.

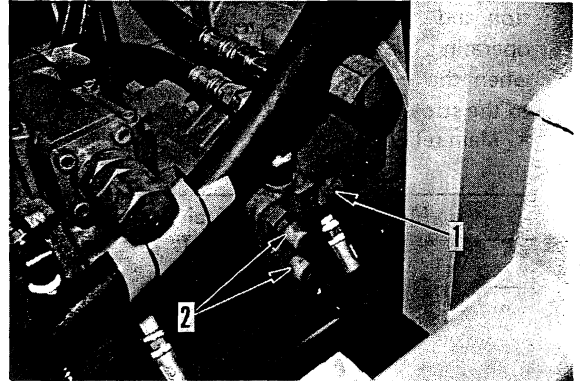

## CHECKING CHARGE RELIEF VALVE

★ Applicable to MST-600, 700, 800, 1100, 1500 and 2000.

- If the oil pressure warning lamp on the instrument panel lights up or in the event of such trouble as the vehicle does not move, lacks power, and so on, check the main pump's charge relief valve as follows.
1. Operate the travel lever to the "NEUTRAL" position and stop the engine.
  2. **Check the charge relief valve**  
Remove the plug (1) and draw out the poppet (2) and check the charge relief valve for biting-in of dust, foreign matter, etc., seat abrasion, spring (3) breakdown or dilation, etc.

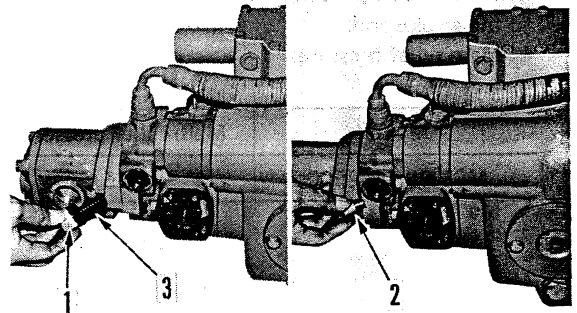
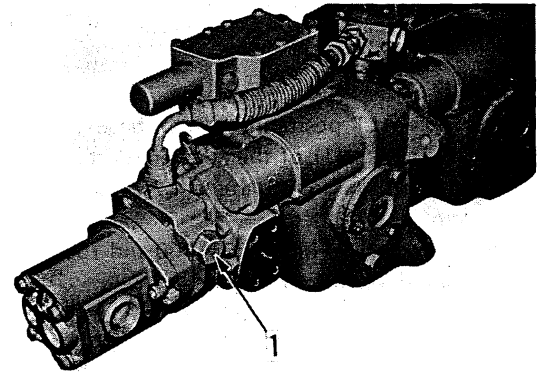

## CHECKING CHECK VALVE

★ Applicable to MST-600, 700, 800, 1100, 1500 and 2000

- In the event of such trouble as the vehicle does not move, lacks power, and so on, check the main pump's check valve as follows.

1. Operate the travel lever to the "NEUTRAL" position and stop the engine.

2. **Check the front pump check valve**

Remove the check valve (1) and check it for catching of dust, foreign matter, etc., the ball and sleeve seat abrasion, etc.

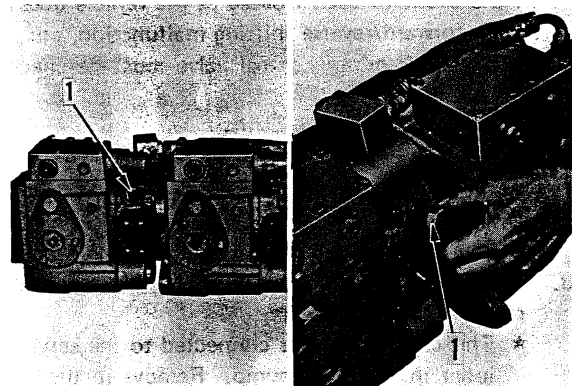

3. **Check the rear pump check valve**

1) Disconnect the hydraulic piping and remove the charging pump (2) by removing 2 bolts.

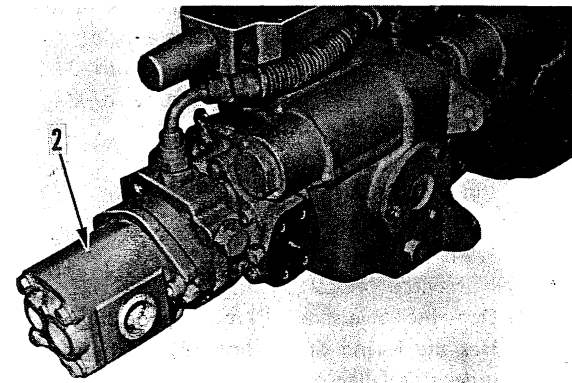

2) Disconnect the charging port block (3).

3) Remove 2 sets of check valves (4) and check them for biting-in of dust, foreign matter, etc., spring breakdown or dilation, ball abrasion, etc.

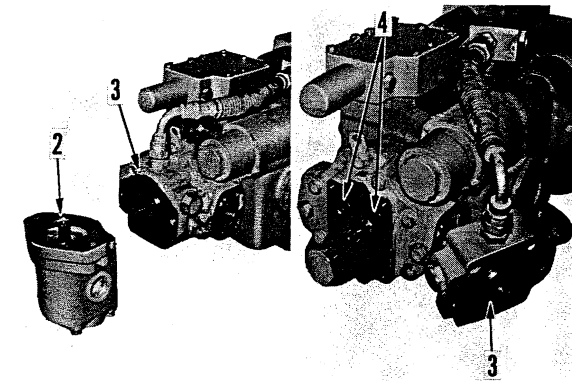



## CHECKING PUMP CONTROL VALVE

★ Applicable to MST-600, 700, 800, 1100, 1500 and 2000

● In the event of such trouble as the vehicle does not move, forward/reverse shifting malfunction, etc., the main pump's pump control valve must be checked. Check it as follows.

1. Operate the travel lever to the "NEUTRAL" position and stop the engine.
2. Disconnect the travel lever's control linkage on the pump side.
3. Remove the main pump's pump control valve (1) by removing its fixing bolts.

★ The control valve is connected to the servo cylinder in the main pump. Remove it, therefore, after drawing out the pin of the lever (2) on the valve side from the hole in the link on the cylinder side while lifting the valve a little.

★ The control valve is equipped with 3 sets of orifices. When removing the valve, therefore, hold down the orifice (3) and the O-ring with your finger taking care not to let them drop into the pump interior.

4. Check the control valve for the following.
  - 1) Is the orifice (3) hole clogged?
  - 2) Is the control shaft's (4) spring pin broken?
  - 3) Does the valve spool (5) move smoothly?
  - 4) Has the E-ring of the link (6) on the servo cylinder side fallen off?

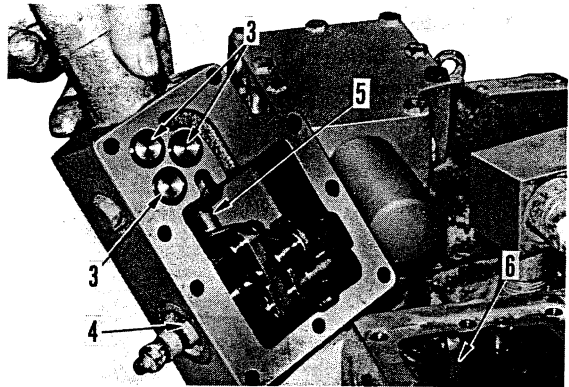
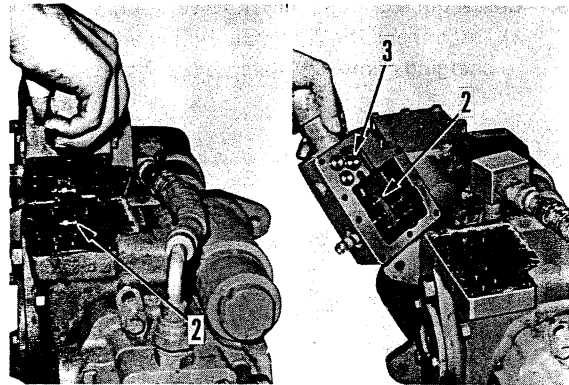
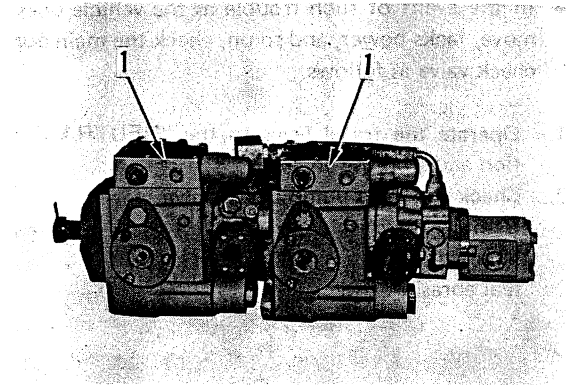

## CHECKING SERVO CYLINDER

★ Applicable to MST-600, 700, 800, 1100, 1500 and 2000

● In the event of such trouble as the vehicle does not move, forward/reverse shifting malfunction, etc., check the functioning of the servo cylinder in the main pump as follows.

1. Operate the travel lever to the "NEUTRAL" position and stop the engine.
2. Disconnect the travel lever's control linkage on the pump side.
3. Remove the valve referring to the item on the checking pump control valve.
4. Insert a bar ①, etc., between the servo cylinder (1) and the pump body and engage the tip of the bar with the servo cylinder.
5. Check whether the servo cylinder (1) moves smoothly or not by trying to move it back and forth using the bar ① as a lever the fulcrum of which is the pump body.
  - ★ If the operating force is too light, the cylinder piston spring may break.
  - ★ If the operating force is too heavy, the servo cylinder may possibly seize up or make a one-sided contact.

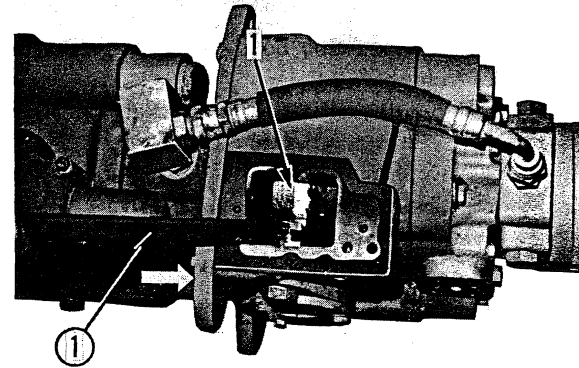
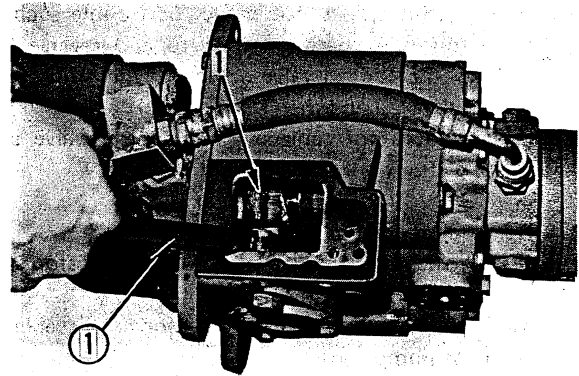

## REPLACING AND ADJUSTING PUMP CONTROL VALVE

### ★ Applicable for MST-2500

- If the machine does not move, or trouble such as failure to switch between forward and reverse has occurred, the control valve on top of the main pump must be checked and then replaced.

The procedure for replacing the control valve and adjusting after replacement is as follows.

### 1. Removal of control valve

- 1) Set the travel lever at neutral and stop the engine.
- 2) Disconnect control linkage (1) for the travel lever at the pump end.
- 3) Disconnect rubber hoses (2) and (3).
  - ★ Put blind plugs in the hoses after disconnecting them.
- 4) Remove mounting bolt (4), then remove lever (6) from shaft (5).
  - ★ Mounting bolt: Hexagon socket head screw (M5 x 20)
- 5) Remove 4 mounting bolts (7), then remove control valve (8) from the pump housing.
  - ★ Mounting bolt: Hexagon socket head screw (M6 x 20)

### 2. Installing control valves

- 1) Insert rod (9) in the groove of the servo cylinder, install control valve (8) to the pump housing, then tighten 4 mounting bolts (7).
- ★ Tightening torque: 1.2 – 1.5 kgm
- 2) Install lever (6) to shaft (5), then tighten mounting bolt (4) temporarily.
  - ★ Tighten the mounting bolt fully after adjusting the zero point.
- 3) Connect rubber hoses (3) and (2).
- 4) Connect control linkage (1) of the travel lever.

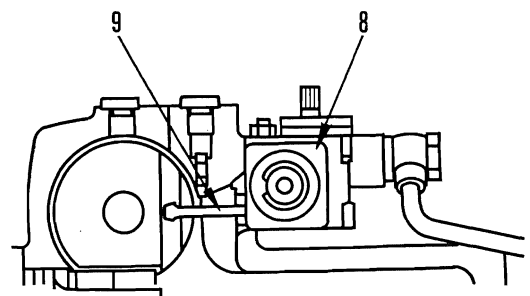
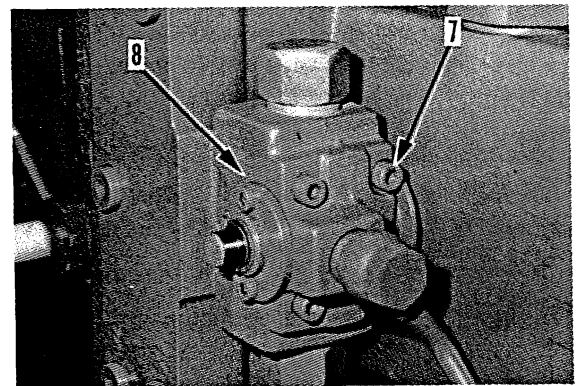
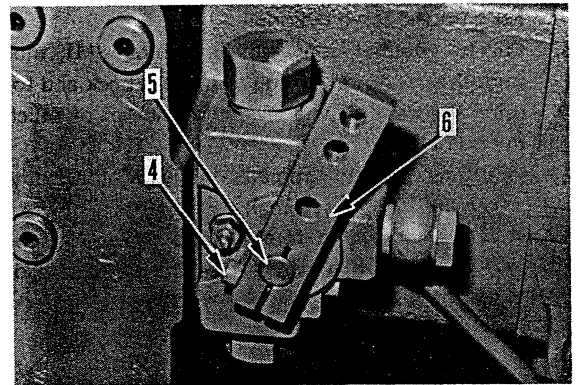
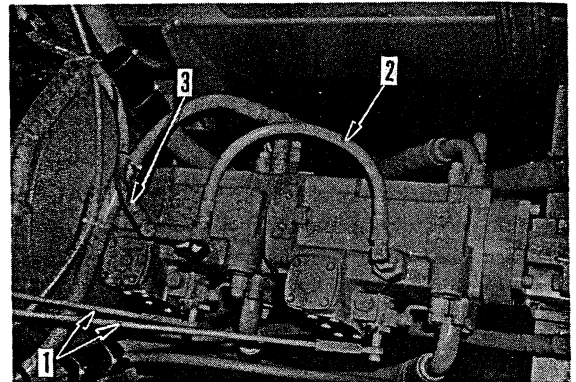

### 3. Bleeding air from servo cylinder

After replacing the control valve, always bleed the air from the servo cylinder as follows.

- 1) Start the engine and run at approx. 1000 rpm.
- 2) With the parking brake lever engaged, operate the steering lever 4 – 5 times between forward and reverse.

### 4. Adjustment method (Adjustment of zero point)

Adjust as follows.

- 1) Install hydraulic gauges (500 kg/cm<sup>2</sup>) to main pump ports A1 and B1 (or A2 and B2).

★ Screw size of ports A1 and B1: M18 x 1.5

★ Using an Uchida Yuatsu bushing (Part No.: 110076195), make the screw size PT 3/8.

- 3) Start the engine and run at approx. 1000 rpm, then adjust with adjustment screw (10) of the control valve so that the pressure gauges at both ports A1 and B1 are approx. 20 kg/cm<sup>2</sup>.

★ Loosen nut (11), screw in adjustment screw fully, then turn it back one turn.

(The adjustment can be made within one turn.)

- 4) When ports A1 and B1 are the same pressure, lock adjustment screw (10) with nut (11).

★ Tightening torque of nut: 1.0 kgm

- 5) Remove the pressure gauges and bushing, and install blind plugs in ports A1 and B1.

★ This is the method for adjusting the zero point of shaft (5) and barrel (12), and the zero point of the pump angle. Always carry out this adjustment when the control valve has been replaced.

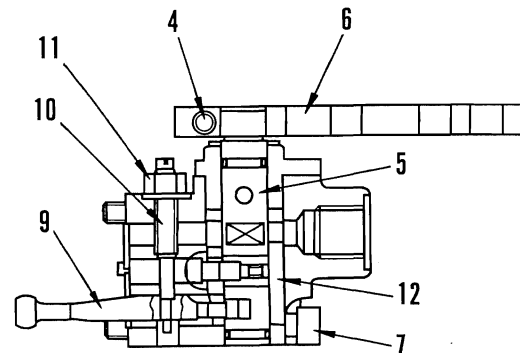
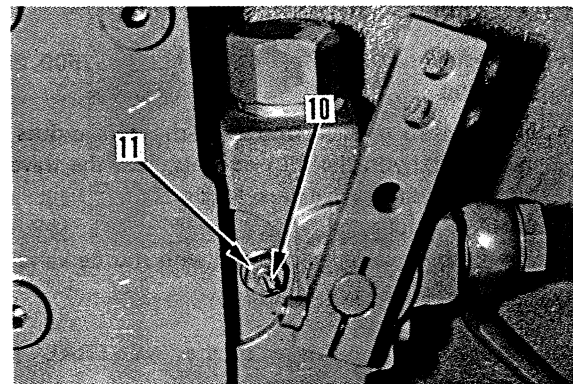
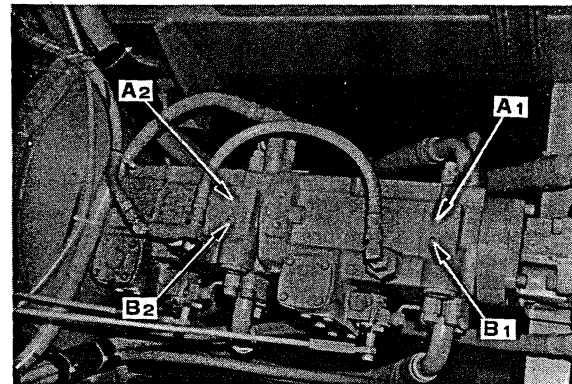

- |                        |                      |
|------------------------|----------------------|
| 4. Lever mounting bolt | 9. Rod               |
| 5. Shaft               | 10. Adjustment screw |
| 6. Lever               | 11. Locknut          |
| 7. Valve mounting bolt | 12. Barrel           |

# CHECKING TRAVEL MOTOR PARTS

## CHECKING HIGH-PRESSURE RELIEF VALVE

★ Applicable to MST-600, 700, 800, 1100, 1500 and 2000

- In the event of such trouble as the vehicle does not move, lacks power, etc., check the traveling motor's high-pressure relief valve as follows.
1. Operate the travel lever to the "NEUTRAL" position and stop the engine.
  2. Remove the high-pressure relief valve (1) and check it for catching of dust, foreign matter, etc., spring breakdown or dilation, seat abrasion, etc.

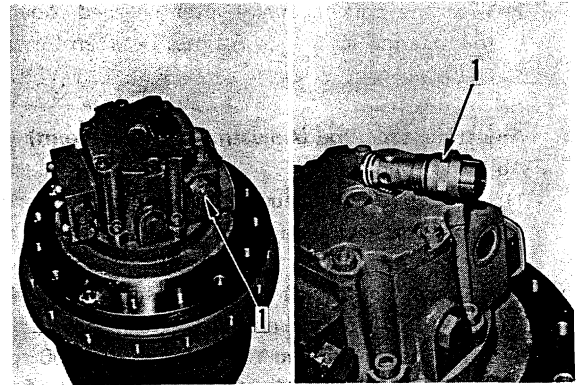

## CHECKING FLUSHING VALVE

★ Applicable to MST-600, 700, 800, 1100, 1500, 2000 and 2500

- In the event of such trouble as the vehicle does not move, the hydraulic oil overheats, etc., the traveling motor's flushing valve must be checked. Check it as follows.
  - The flushing valve is equipped with shuttle valve and charge relief valve.
1. Operate the travel lever to the "NEUTRAL" position and stop the engine.
  2. **Check the shuttle valve**  
Remove the plug (1) and draw out the shuttle valve and check it for biting-in of dust, foreign matter, etc., spool (2) abrasion, spring (3) breakdown or dilation, etc. In addition, check whether the shuttle valve operates smoothly or not by pushing the spool with your finger.
  3. **Check the charge relief valve**  
Remove the plug (4) and draw out the poppet (5) and check the charge relief valve for catching of dust, foreign matter, etc., seat abrasion, spring (6) breakdown or dilation, etc.

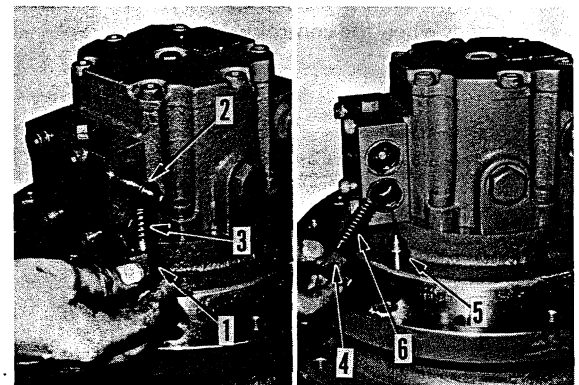
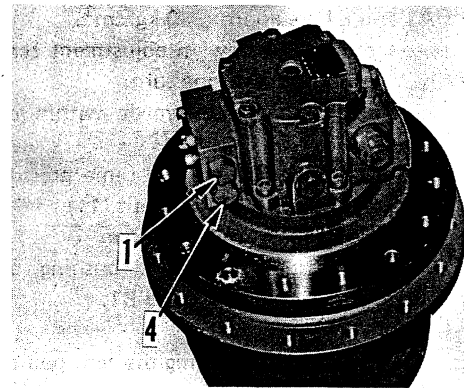

## TEST RUN OF HST

- ★ Applicable to MST-600, 700, 800, 1100, 1500 and 2000
  - ★ Test run the HST as follows whenever a hydraulic motor, travel motor, piping etc., is replaced.
1. Fill the hydraulic oil tank with oil and check that oil flows out by loosening the sucking part of the charging port piping (1). Then, tighten the piping.
    - ★ If oil is put into the hydraulic oil tank, air in the circuit escapes and the oil is sucked into the case.
  2. Remove the front and rear main pump case drain plugs (2) and the right and left travel motor drain plugs (3), fill each case with oil and connect the piping.
  3. The main pump must be left at the "NEUTRAL" position and the control linkage (4) must be left disconnected.
  4. Connect each piping securely.
  5. Remove the main pump housing's charging pressure port plug (5) and install the oil pressure gauge (50 kg/cm<sup>2</sup>).
    - ★ Plug screw size: 7/16-20 UNF
  6. Start the engine and run it at the lowest possible speed and check that the charging pressure is at least 10 kg/cm<sup>2</sup>.
    - ★ Never raise the engine speed before the HST circuit is filled sufficiently with oil, or seizure will result.
  7. Raise the engine speed to about 1,000 rpm and check that the charging pressure is within the range of 13 - 14 kg/cm<sup>2</sup>.
  8. Stop the engine and connect the control linkage (4).
    - ★ Check the lever on the pump side, which must be at the "NEUTRAL" position.
  9. Set the travel lever to the "NEUTRAL" position and restart the engine. Raise the speed to 1,500 - 2,000 rpm and run for several minutes under no load.
    - ★ The main pump is run in order to bleed the circuit completely of air.
  10. Operate the travel lever slowly to the forward/reverse position and check that it interlocks with the direction of rotation of the motor.
    - ★ The charging pressure reading is 16 - 18 kg/cm<sup>2</sup> while the main pump is running.
  11. Apply load gradually after checking that no bubbles enter the hydraulic oil tank.
    - ★ Check the oil level in the hydraulic oil tank and add oil, if necessary, up to the specified level. Tighten the cap securely after adding oil.
    - ★ If bubbles in the tank don't disappear and the oil is turbid and white, air must have been sucked in from the suction side. In such a case, check.

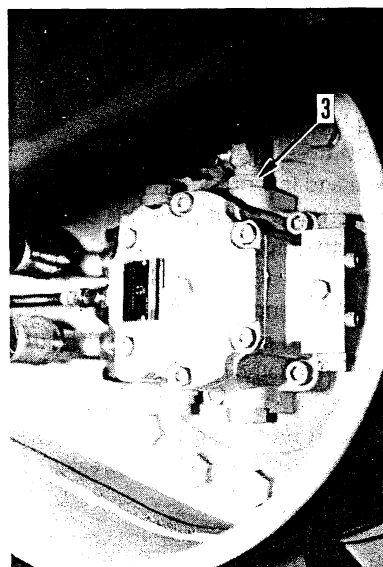
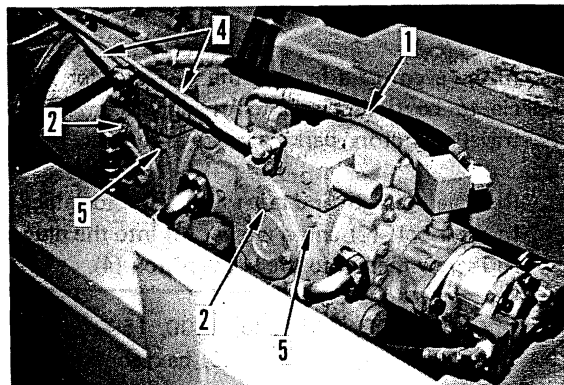

# HOW TO RELEASE PARKING BRAKE

## ★ Excluding MST-500

- In the event of a fault in the HST and for the vehicle to be transported to a safe place, release the traveling motors' parking brake as follows.

1. Remove the right and left traveling motor plugs (1).
2. Insert a bolt (2) and a washer (3) into the plug hole and screw them into the brake piston (4).

### ★ Bolt size and type:

- MST-600, 700, 800, 1100, 1500 and 2000: M10 x 25, Pitch = 1.5, hexagon socket head cap screw
- MST-2200 and 2500: M10 x 65, Pitch = 1.5, hexagon socket head cap screw

3. As you turn the bolt (2) about twice, the brake piston (4) is pulled towards the cover side and the parking brake is released.
4. Connect hoses between the travel motor's high-pressure and low-pressure sides.

★ For a short circuit, one side of the hose connected to the motor should be disconnected and the pump side of the remaining side should be disconnected and then connected to the motor.

Carry it out on either of the right or left sides.

★ After manually releasing the parking brake, the vehicle must not be moved a long distance. Rather it must be moved just several meters to a safe place, or the HST will break.

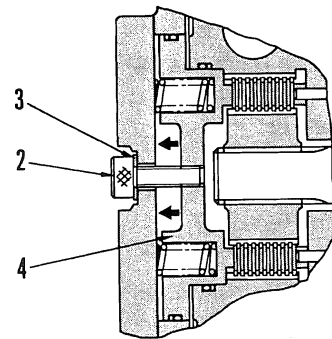
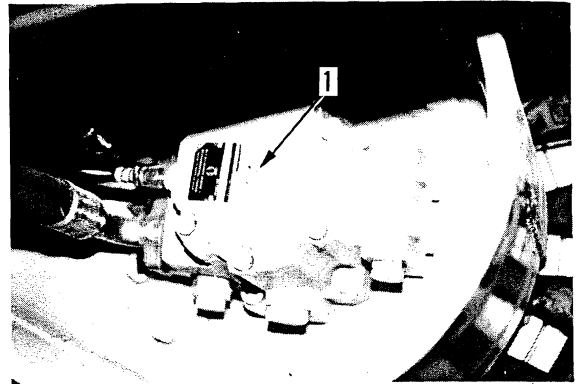

---

# 30 TROUBLESHOOTING

---

Troubleshooting procedure .....	30- 2
Check before troubleshooting table .....	30- 2
Troubleshooting	
1. Machine does not move in any direction, and dump cylinder also does not move. ....	30- 3
2. Machine does not move in any direction, but dump cylinder moves. ....	30- 4
3. Dump cylinder does not move, but machine moves. ....	30- 6
4. Left (right) travel motor does not move at all. ....	30- 7
5. Left (right) travel motor does not move in forward (reverse) direction. ....	30- 8
6. When steering lever is set at neutral, steering does not return to neutral. ....	30-10
7. Machine travels only in forward (reverse) direction. ....	30-10
8. Machine steers to one side and does not travel in a straight line. ....	30-10
9. Engine stops. ....	30-11
10. Machine lacks power. ....	30-12
11. Machine sometimes does not move. ....	30-14
12. When traveling at low speed, the machine jerks. ....	30-14
13. Response of steering lever is poor. ....	30-15
14. Operating force for steering lever is abnormally heavy. ....	30-15
15. Hydraulic oil overheats. ....	30-16
16. Parking brake cannot be released. ....	30-18
17. Parking brake does not take effect. ....	30-19
18. Abnormal noise generated. ....	30-20
19. Hydraulic hose vibrates. ....	30-21
20. Hydraulic charge lamp in operator's compartment lights up. ....	30-22
21. Rubber crawler often comes off. ....	30-23
22. Even when the low/high speed selector switch is set to HIGH speed does not change. ....	30-24
23. Battery does not charge. ....	30-26



## TROUBLESHOOTING PROCEDURE

Carry out troubleshooting in the following order.

1. If a request for repairs has been received, first ask about the following items.
  - Name of customer
  - Model and serial number of machine
  - Details of jobsite, etc.
2. Get an outline of the problem.
  - Symptoms of failure
  - Details of work being carried out when problem occurred
  - Operating environment
  - Previous repairs, details of maintenance, etc.
3. Prepare the necessary tools.
  - Jigs, testers, hydraulic kits, etc.
4. Try to re-enact the problem.
  - Operate the machine in the same way (travel, work) to check the symptoms.
5. Use the CHECKS BEFORE TROUBLESHOOTING TABLE to locate simple problems, and carry out repairs.
  - Checks before starting
  - Other check items
6. Carry out troubleshooting (full troubleshooting)
  - Select troubleshooting item that matches symptoms, and carry out troubleshooting.

### Method of using troubleshooting chart

1. Select the problem symptoms from the troubleshooting Table of Contents.
2. First, carry out the checks written under the problem, then carry out troubleshooting according to the troubleshooting flow.
3. If the result of the inspection or measurement inside  is YES, go to the  on the upper and if it is NO, go to the  below.
4. The Action column on the right side gives the action to take for the result of the inspection or measurement.
5. The precaution items for troubleshooting are marked ★ under the frame.

## CHECKS BEFORE TROUBLESHOOTING TABLE

	Item	Action
Checks before starting	1. Check fuel level	Add fuel
	2. Check for impurities in fuel	Clean, drain
	3. Check hydraulic oil level	Add oil
	4. Check hydraulic strainer	Clean, drain
	5. Check engine oil level	Add oil
	6. Check coolant level	Add water
	7. Check dust indicator	Clean, replace
	8. Check for loose or corroded wiring of electrical equipment	Tighten, replace
Other check items	1. Abnormal noise or smell from pump, motor	Repair
	2. Check for leakage of oil from equipment or hydraulic piping	Repair, replace
	3. Check charge line filter	Clean, replace
	4. Bleeding of air	Bleed air
	5. Check battery voltage (20 – 30V)	Charge, replace
	6. Check battery electrolyte level	Add, replace
	7. Check electrical wiring	Repair, replace
	8. Check for blown or corroded fuses	Replace

# 1. Machine does not move in any direction, and dump cylinder also does not move.

Ask the operator the following points.

- Did the machine suddenly stop moving? Yes = Component seized or broken
- Was there any abnormal noise when the machine stopped moving? (From what area?) Yes = Component broken.

## Checks before troubleshooting

- Is oil level in hydraulic tank correct?
- Is there interference or disconnection of steering control linkage?
- Is there damage or leakage from piping between charge pump and dump control valve?

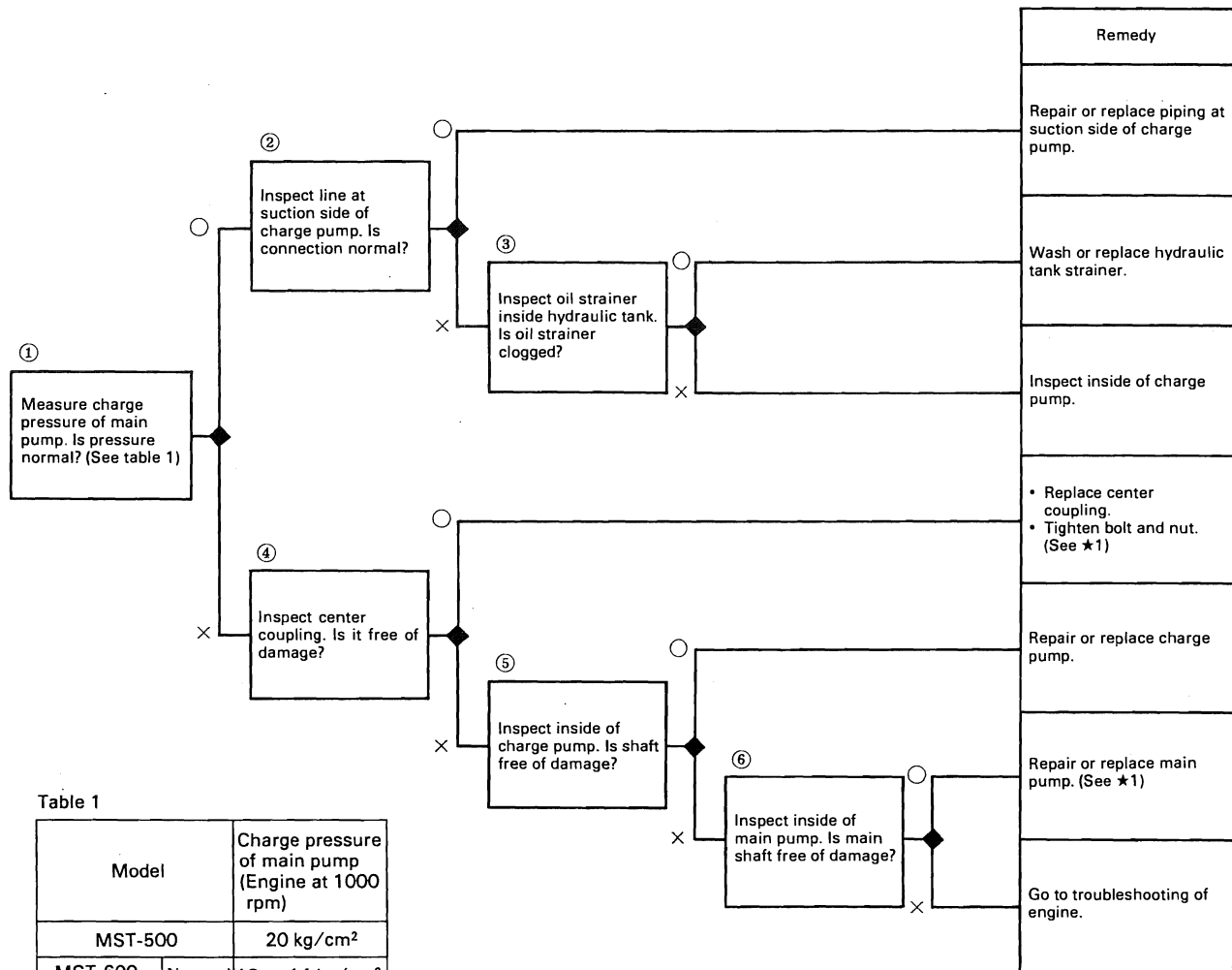



Table 1

Model	Charge pressure of main pump (Engine at 1000 rpm)
MST-500	20 kg/cm <sup>2</sup>
MST-600	Neutral 13 — 14 kg/cm <sup>2</sup>
MST-2000	On load 11 — 13 kg/cm <sup>2</sup>
MST-2200, 2500	25 kg/cm <sup>2</sup>

★1: When replacing the main pump, tighten the mounting nut of the center coupling securely.

 kgm Mounting nut: 20 — 24 kgm (MST-600 — MST-1500)  
51 — 59 kgm (MST-2000)

## 2. Machine does not move in any direction, but dump cylinder moves.

Ask the operator the following points.

- Did the machine suddenly stop moving? Yes = Component seized or broken
- Was there any abnormal noise when the machine stopped moving? (From what area?) Yes = Component broken.

### Checks before troubleshooting

- Is oil level in hydraulic tank correct?
- Is there interference or disconnection of steering control linkage?
- Is there damage or leakage from piping between dump control valve and main pump?
- Is there damage or leakage from piping between main pump and travel motor?
- Is there damage or leakage from parking brake piping?

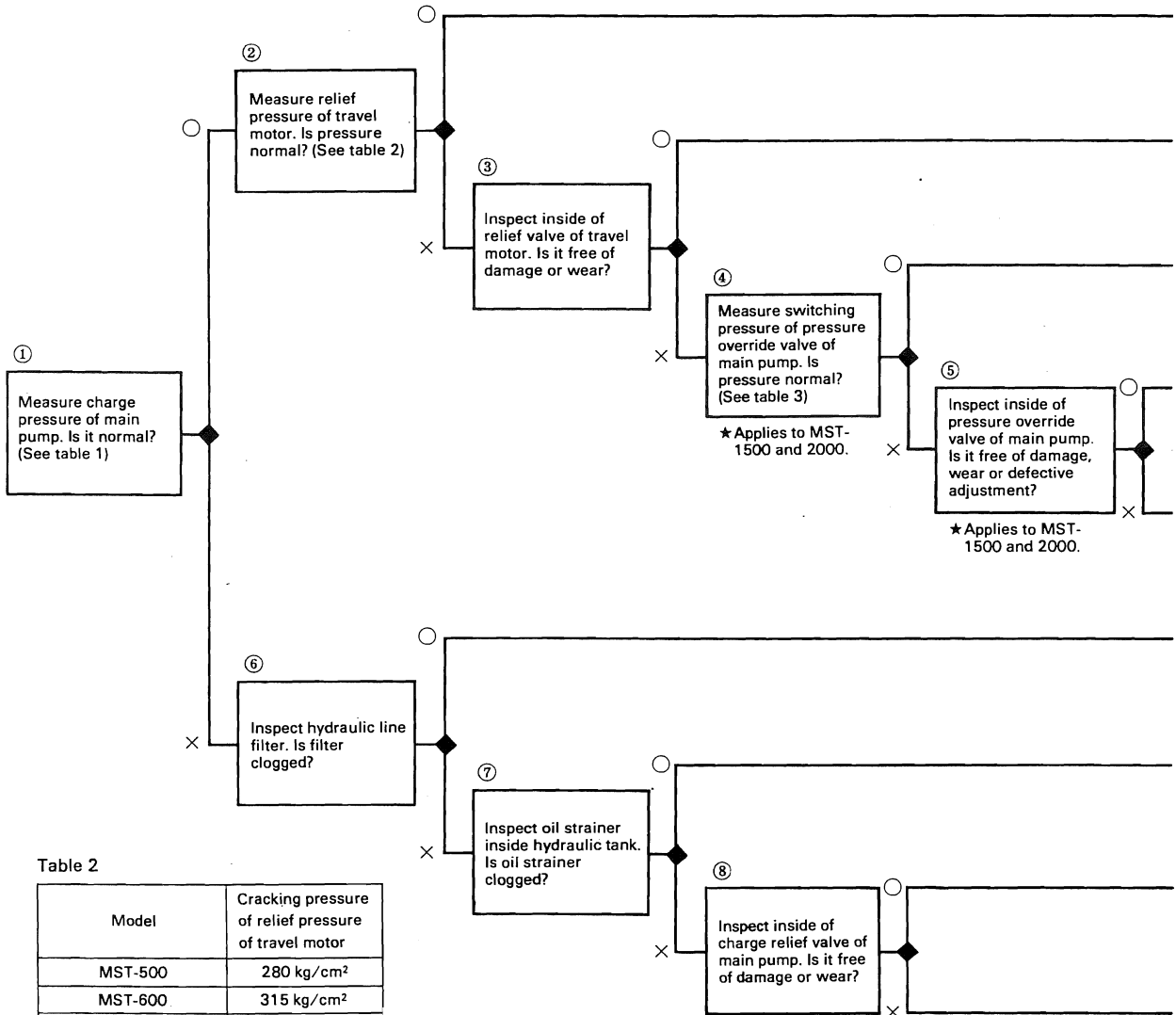

Table 2

Model	Cracking pressure of relief pressure of travel motor
MST-500	280 kg/cm <sup>2</sup>
MST-600	315 kg/cm <sup>2</sup>
MST-700, MST-800	350 kg/cm <sup>2</sup>
MST-1100	385 kg/cm <sup>2</sup>
MST-1500 (#15001—15164)	385 kg/cm <sup>2</sup>
MST-1500 (#15165—)	350 kg/cm <sup>2</sup>
MST-2000 (#K20101—20126, 20128) (#M02101—02104)	385 kg/cm <sup>2</sup>
MST-2000 (#K20127, 20129—) (#M02105—)	350 kg/cm <sup>2</sup>
MST-2200	325 kg/cm <sup>2</sup>
MST-2500	350 kg/cm <sup>2</sup>

Table 1

Model	Charge pressure of main pump (Engine at 1000 rpm)
MST-500	20 kg/cm <sup>2</sup>
MST-600	Neutral 13 — 14 kg/cm <sup>2</sup>
MST-2000	On load 11 — 13 kg/cm <sup>2</sup>
MST-2200, 2500	25 kg/cm <sup>2</sup>

Table 3

Model	Cracking pressure of pressure override valve
MST-1500 (#15094—15164)	370 kg/cm <sup>2</sup>
MST-1500 (#15165—)	350 kg/cm <sup>2</sup>
MST-2000 (#K20101—20126, 20128) (#M02101—02104)	370 kg/cm <sup>2</sup>
MST-2000 (#K20127, 20129—) (#M02105—)	350 kg/cm <sup>2</sup>

	Remedy
	Replace the travel motor, and if the condition does not return to normal, inspect the main pump.
	Repair or replace relief valve of travel motor. (See ★2)
	Replace the travel motor, and if the condition does not return to normal, inspect the main pump.
	Repair or replace pressure override valve of main pump. (See ★2)
	Replace the travel motor, and if the condition does not return to normal, inspect the main pump. (See ★1)
	Replace element of hydraulic line filter.
	Wash or replace oil strainer inside hydraulic tank.
	Repair or replace charge relief valve of main pump. (See ★2)
	Go to No.2 of troubleshooting.

★1: When replacing the main pump, tighten the mounting nut of the center coupling securely.

 Mounting nut: 20 – 24 kgm (MST-600 – MST-1500)  
51 – 59 kgm (MST-2000)

★2: When checking or replacing any valve, always check that there is no dirt or dust caught in it.

### 3. Dump cylinder does not move, or does not move properly, but machine moves.

Ask the operator the following points.

- Did the cylinder suddenly stop moving? Yes = Component seized or broken
- Was there any abnormal noise when the cylinder stopped moving? (From what area?) Yes = Component broken.
- Was the speed of the carrier slow before? Yes = Parts worn

#### Checks before troubleshooting

- Is oil level in hydraulic tank correct?
- Is there excessive play, breakage at dump lever pin?
- Is there damage or leakage from piping between dump control valve and dump cylinder?

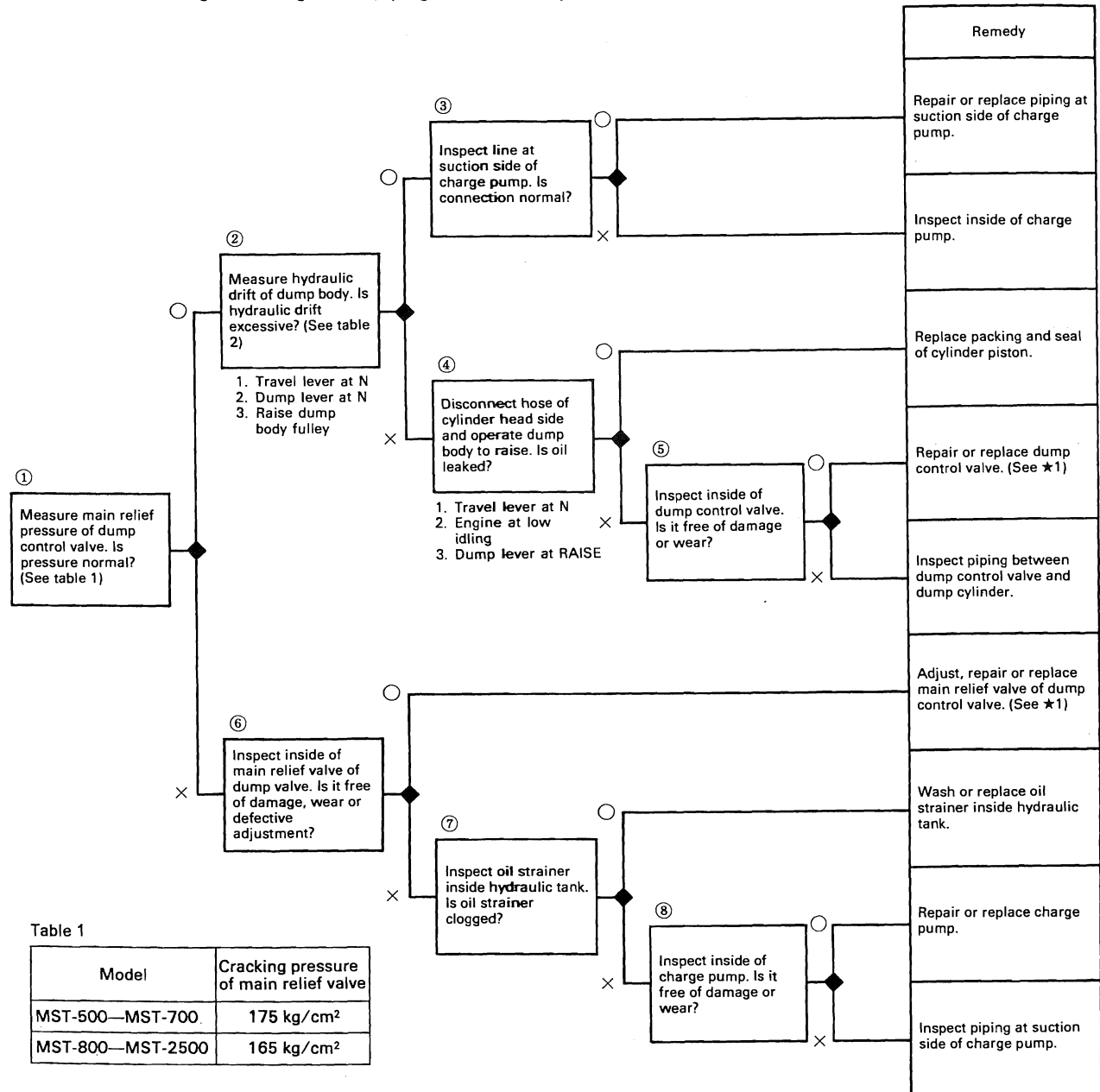

Table 1

Model	Cracking pressure of main relief valve
MST-500—MST-700	175 kg/cm <sup>2</sup>
MST-800—MST-2500	165 kg/cm <sup>2</sup>

Table 2

Model	Hydraulic drift
All models	20 mm (5 min.)

★1: When checking or replacing any valve, always check that there is no dirt or dust caught in it.

#### 4. Left (right) travel motor does not move at all.

Ask the operator the following points.

- Did the motor suddenly stop moving? Yes = Component seized or broken
- Was there any abnormal noise when the motor stopped moving? (From what area?) Yes = Component broken.

#### Checks before troubleshooting

- Is oil level in hydraulic tank correct?
- Is there interference or disconnection of steering control linkage?
- Is there damage or leakage from piping between main pump and travel motor?
- Is there damage or leakage from parking brake piping?

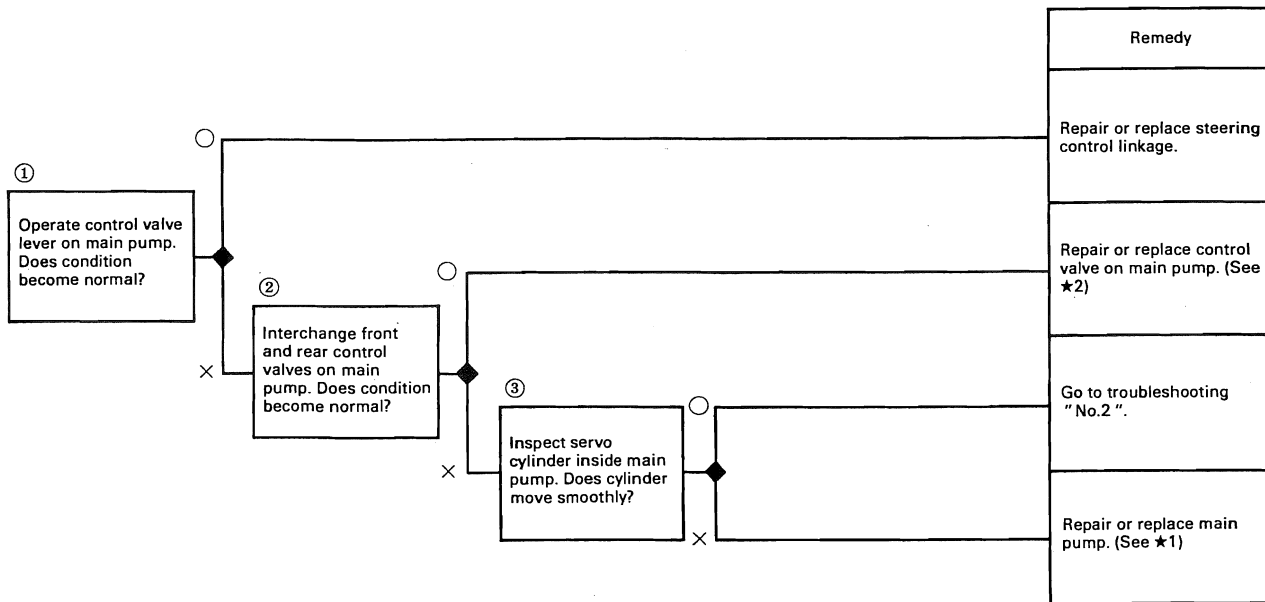

★1: When replacing the main pump, tighten the mounting nut of the center coupling securely.

 Mounting nut: 20 – 24 kgm (MST-600 – MST-1500)  
51 – 59 kgm (MST-2000)

★2: When checking or replacing any valve, always check that there is no dirt or dust caught in it.

## 5. Left (right) travel motor does not move in forward (reverse) direction.

### Ask the operator the following points.

- Did the motor suddenly stop moving? Yes = Component seized or broken
- Was there any abnormal noise when the motor stopped moving? (From what area?) Yes = Component broken.

### Checks before troubleshooting

- Is oil level in hydraulic tank correct?
- Is there interference or disconnection of steering control linkage?
- Is there damage or leakage from piping between main pump and travel motor?
- Is there damage or leakage from parking brake piping?

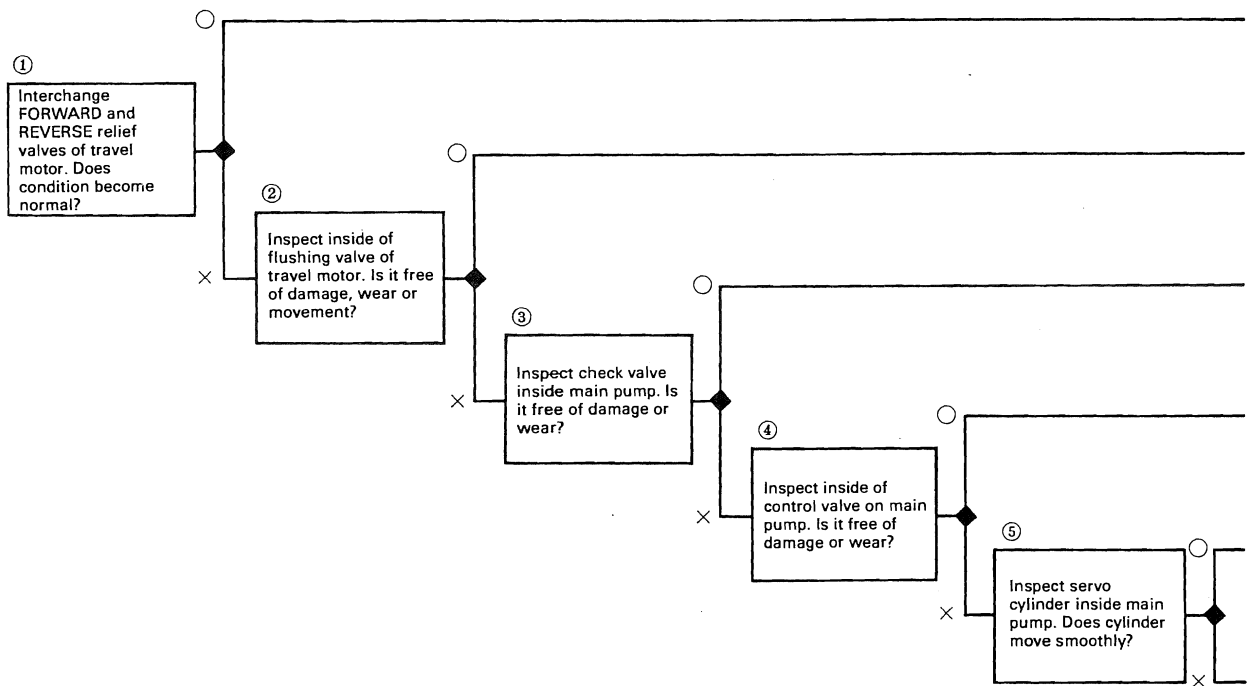

	Remedy
	Repair or replace relief valve of travel motor. (See ★2)
	Repair or replace flushing valve inside travel motor. (See ★2)
	Repair or replace check valve inside main pump. (See ★2)
	Repair or replace control valve on main pump. (See ★2)
	Replace the travel motor, and if the condition does not return to normal, inspect the main pump.
	Replace the travel motor, and if the condition does not return to normal, inspect the main pump.

★1: When replacing the main pump, tighten the mounting nut of the center coupling securely.

 kgm Mounting nut: 20 – 24 kgm (MST-600 – MST-1500)  
51 – 59 kgm (MST-2000)

★2: When checking or replacing any valve, always check that there is no dirt or dust caught in it.



6. When steering lever is set at neutral, steering does not return to neutral.
7. Machine travels only in forward (reverse) direction.  
(Does not go into neutral or travel in opposite direction.)
8. Machine steers to one side, and does not travel in a straight line.

Ask the operator the following points.

- Did the problem appear suddenly? Yes = Component seized or broken
- Was there any abnormal noise when the problem appeared? (From what area?) Yes = Component broken.

**Checks before troubleshooting**

- Is oil level in hydraulic tank correct?
- Is there interference or disconnection of steering control linkage?
- Is there damage or leakage from piping between main pump and travel motor?

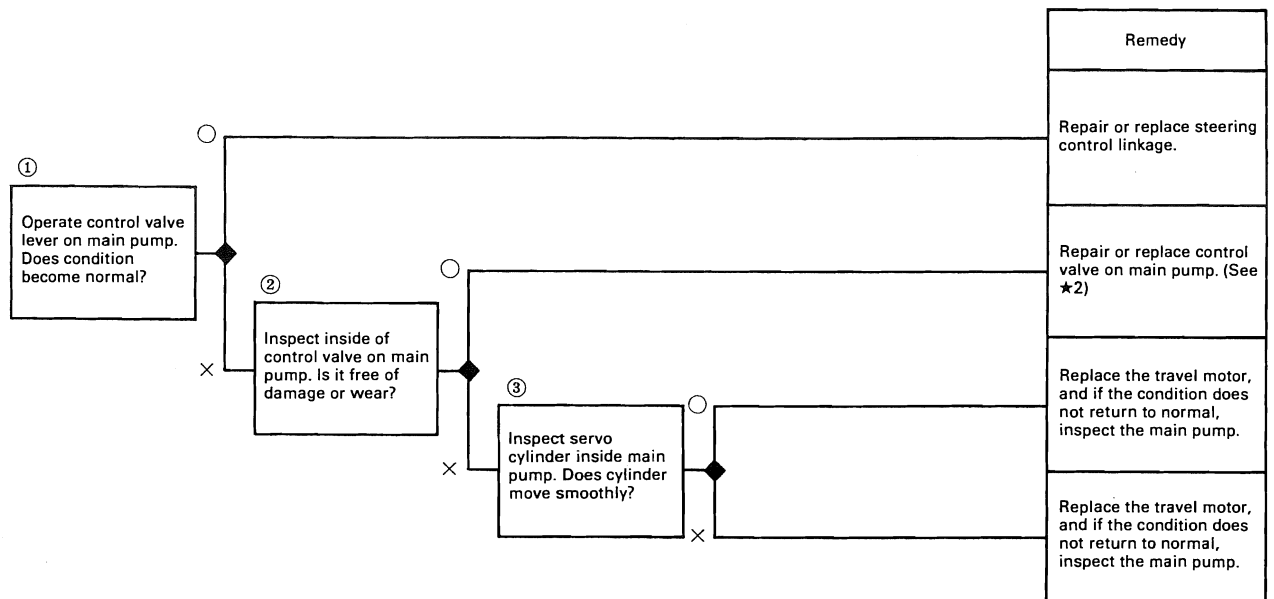

★1: When replacing the main pump, tighten the mounting nut of the center coupling securely.

**kgm** Mounting nut: 20 – 24 kgm (MST-600 – MST-1500)  
51 – 59 kgm (MST-2000)

★2: When checking or replacing any valve, always check that there is no dirt or dust caught in it.

## 9. Engine stops.

★ This is frequently caused by problems with the engine.

Ask the operator the following points.

- Did the engine suddenly stop? Yes = Component seized or broken
- Was there any abnormal noise when the engine stopped? (From what area?) Yes = Component broken.
- Check nature of operation (amount of load), jobsite conditions. Is machine being overloaded?

Checks before troubleshooting

- Is oil level in hydraulic tank correct?
- Is there interference or disconnection of engine control linkage?
- Is there damage or leakage from parking brake piping?
- Is the parking brake applied?

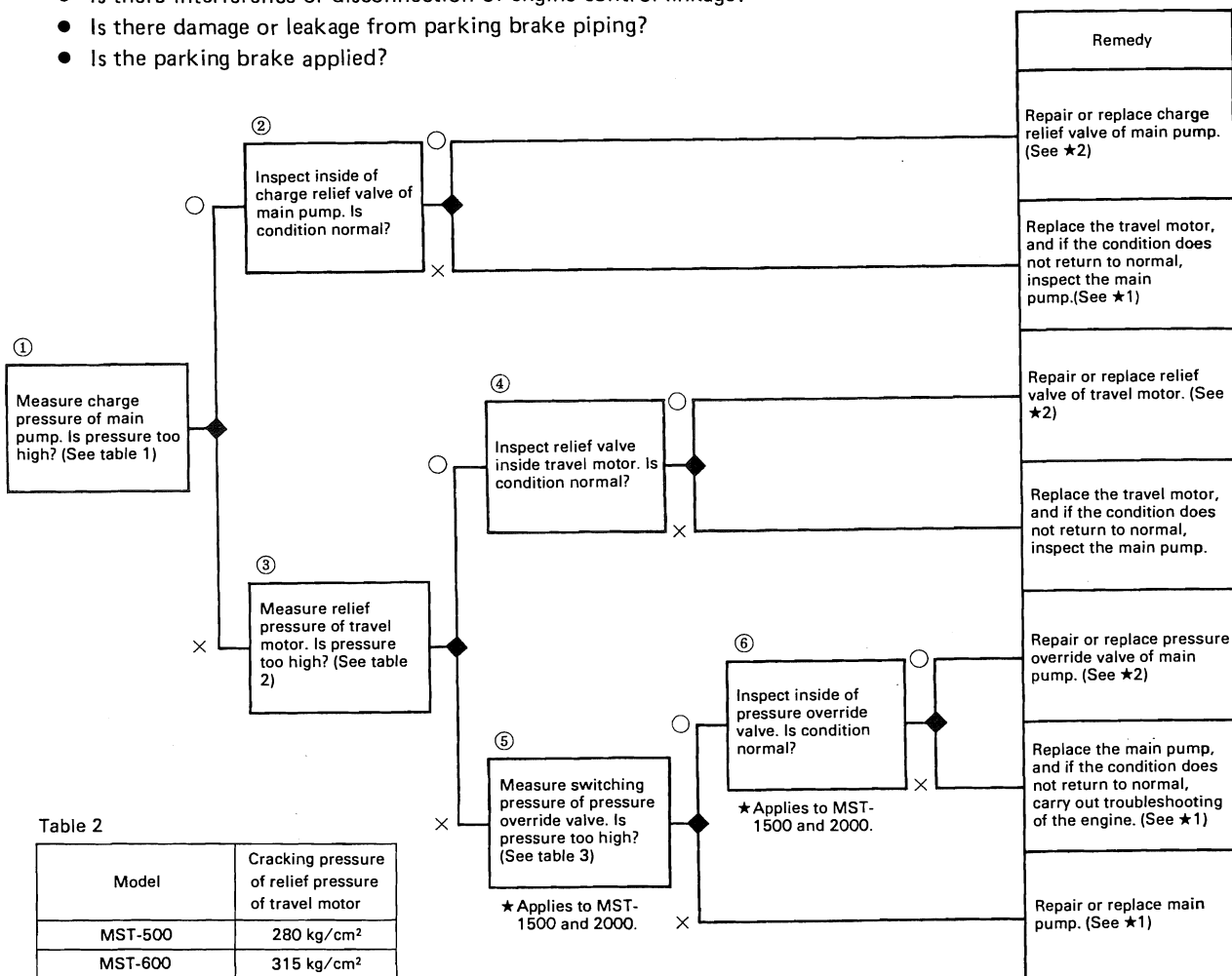

Table 2

Model	Cracking pressure of relief pressure of travel motor
MST-500	280 kg/cm <sup>2</sup>
MST-600	315 kg/cm <sup>2</sup>
MST-700, MST-800	350 kg/cm <sup>2</sup>
MST-1100	385 kg/cm <sup>2</sup>
MST-1500 (#15001—15164)	385 kg/cm <sup>2</sup>
MST-1500 (#15165—)	350 kg/cm <sup>2</sup>
MST-2000 (#K20101—20126, 20128) (#M02101—02104)	385 kg/cm <sup>2</sup>
MST-2000 (#K20127, 20129—) (#M02105—)	350 kg/cm <sup>2</sup>
MST-2200	325 kg/cm <sup>2</sup>
MST-2500	350 kg/cm <sup>2</sup>

Table 1

Model	Charge pressure of main pump (Engine at 1000 rpm)
MST-500	20 kg/cm <sup>2</sup>
MST-600	Neutral 13 — 14 kg/cm <sup>2</sup>
MST-2000	On load 11 — 13 kg/cm <sup>2</sup>
MST-2200, 2500	25 kg/cm <sup>2</sup>

Table 3

Model	Cracking pressure of pressure override valve
MST-1500 (#15094—15164)	370 kg/cm <sup>2</sup>
MST-1500 (#15165—)	350 kg/cm <sup>2</sup>
MST-2000 (#K20101—20126, 20128) (#M02101—02104)	370 kg/cm <sup>2</sup>
MST-2000 (#K20127, 20129—) (#M02105—)	350 kg/cm <sup>2</sup>

★1: When replacing the main pump, tighten the mounting nut of the center coupling securely.

kgm Mounting nut: 20 — 24 kgm (MST-600 — MST-1500)  
51 — 59 kgm (MST-2000)

★2: When checking or replacing any valve, always check that there is no dirt or dust caught in it.

## 10. Machine lacks power.

★ This is frequently caused by problems with the engine.

Ask the operator the following points.

- Did the problem appear suddenly? Yes = Component seized or broken
- Was there any abnormal noise when the problem appeared? (From what area?) Yes = Component broken.
- Check nature of operation (amount of load), jobsite conditions. Is machine being overloaded?

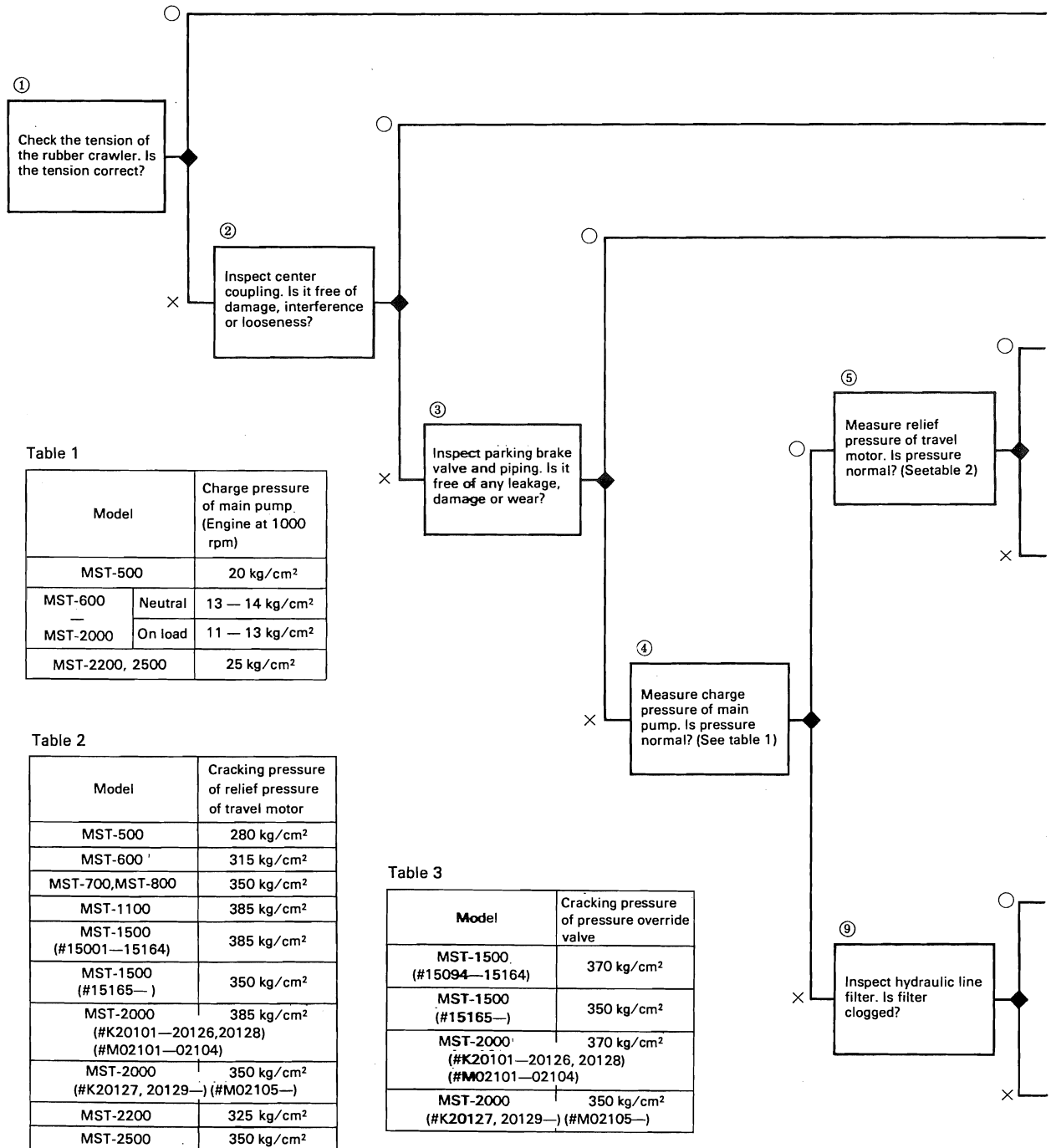

Table 1

Model		Charge pressure of main pump (Engine at 1000 rpm)
MST-500		20 kg/cm <sup>2</sup>
MST-600	Neutral	13 — 14 kg/cm <sup>2</sup>
MST-2000	On load	11 — 13 kg/cm <sup>2</sup>
MST-2200, 2500		25 kg/cm <sup>2</sup>

Table 2

Model	Cracking pressure of relief pressure of travel motor
MST-500	280 kg/cm <sup>2</sup>
MST-600	315 kg/cm <sup>2</sup>
MST-700, MST-800	350 kg/cm <sup>2</sup>
MST-1100	385 kg/cm <sup>2</sup>
MST-1500 (#15001—15164)	385 kg/cm <sup>2</sup>
MST-1500 (#15165—)	350 kg/cm <sup>2</sup>
MST-2000 (#K20101—20126, 20128) (#M02101—02104)	385 kg/cm <sup>2</sup>
MST-2000 (#K20127, 20129—) (#M02105—)	350 kg/cm <sup>2</sup>
MST-2200	325 kg/cm <sup>2</sup>
MST-2500	350 kg/cm <sup>2</sup>

Table 3

Model	Cracking pressure of pressure override valve
MST-1500 (#15094—15164)	370 kg/cm <sup>2</sup>
MST-1500 (#15165—)	350 kg/cm <sup>2</sup>
MST-2000 (#K20101—20126, 20128) (#M02101—02104)	370 kg/cm <sup>2</sup>
MST-2000 (#K20127, 20129—) (#M02105—)	350 kg/cm <sup>2</sup>

★1: When replacing the main pump, tighten the mounting nut of the center coupling securely.

 Mounting nut: 20 — 24 kgm (MST-600 — MST-1500)  
51 — 59 kgm (MST-2000)

★2: When checking or replacing any valve, always check that there is no dirt or dust caught in it.

### Checks before troubleshooting

- Is oil level in hydraulic tank correct?
- Is there interference or disconnection of steering control linkage?
- Is there damage or leakage from hydraulic piping?
- Is there damage or leakage from parking brake piping?
- Is the parking brake applied?
- Is tension of rubber crawler too high?

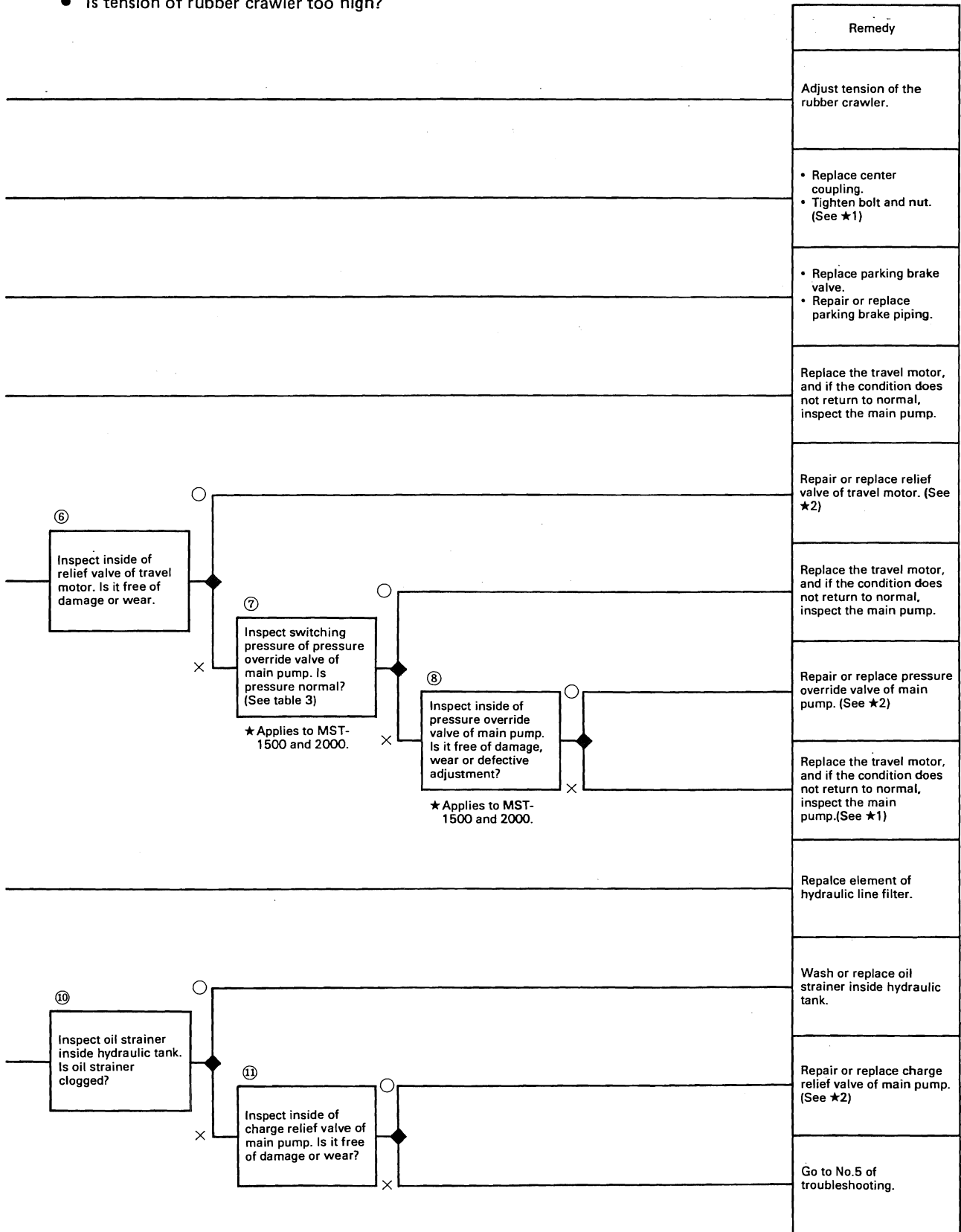

11. Machine sometimes does not move.

12. When traveling at low speed, the machine jerks.

Ask the operator the following points.

- Check nature of operation (amount of load), jobsite conditions. Is machine being overloaded?

Checks before troubleshooting

- Is oil level in hydraulic tank correct?
- Is there interference or disconnection of steering control linkage?
- Is there damage or leakage from parking brake piping?
- Is the parking brake applied?
- Is there damage or linkage from piping between main pump and travel motor?

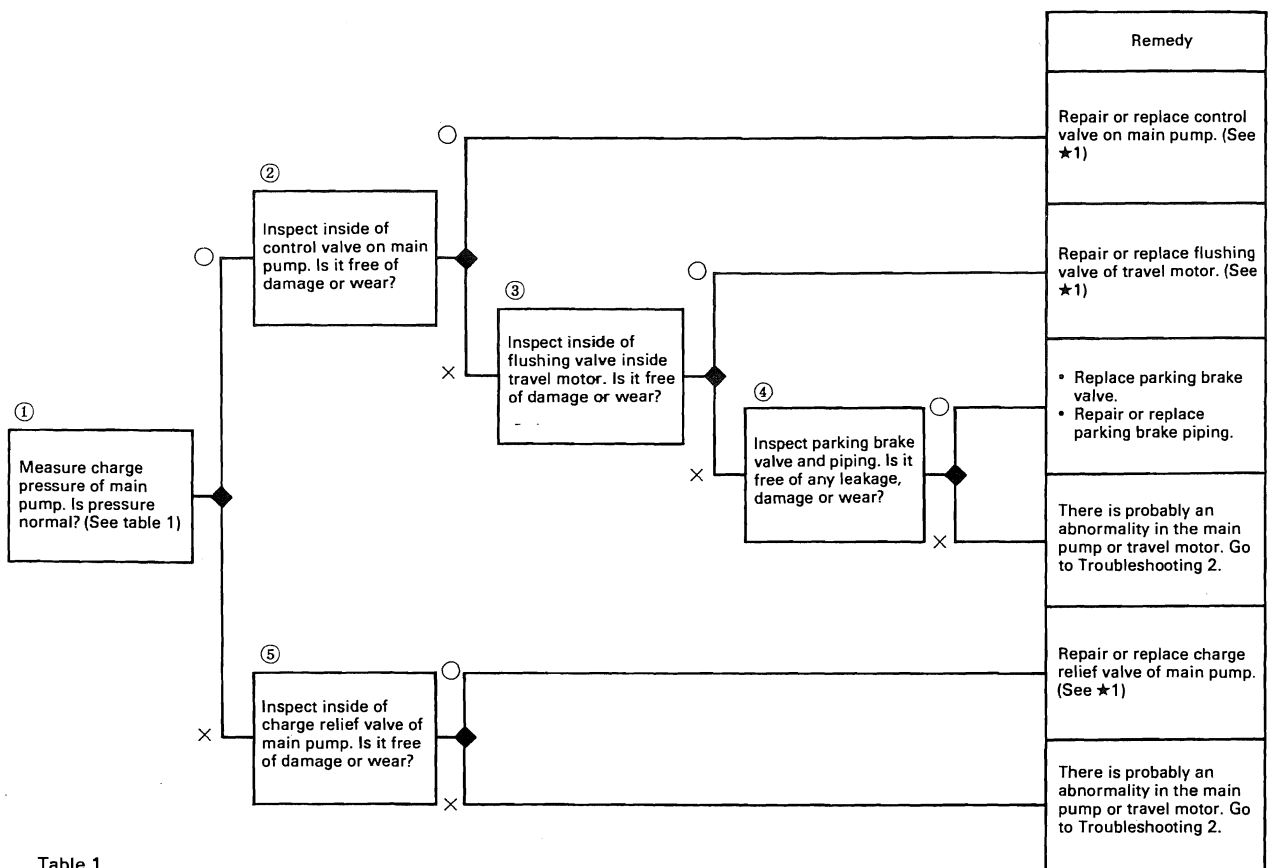

Table 1

Model		Charge pressure of main pump (Engine at 1000 rpm)
MST-500		20 kg/cm <sup>2</sup>
MST-600	Neutral	13 — 14 kg/cm <sup>2</sup>
MST-2000	On load	11 — 13 kg/cm <sup>2</sup>
MST-2200, 2500		25 kg/cm <sup>2</sup>

★1: When checking or replacing any valve, always check that there is no dirt or dust caught in it.

13. Response of steering lever is poor.

14. Operating force for steering lever is abnormally heavy.

Ask the operator the following points.

- Did the response suddenly become poor? Yes = Component seized or broken
- Did the operating force suddenly become heavy? Yes = Component seized or broken
- Was there any abnormal noise when the problem occurred? (From what area?) Yes = Component broken.

Checks before troubleshooting

- Is oil level in hydraulic tank correct?
- Is there interference or disconnection of steering control linkage?
- Is there damage or leakage from parking brake piping?

Checking for abnormalities

- Operate the steering lever and see the actual condition to judge how serious the problem is.

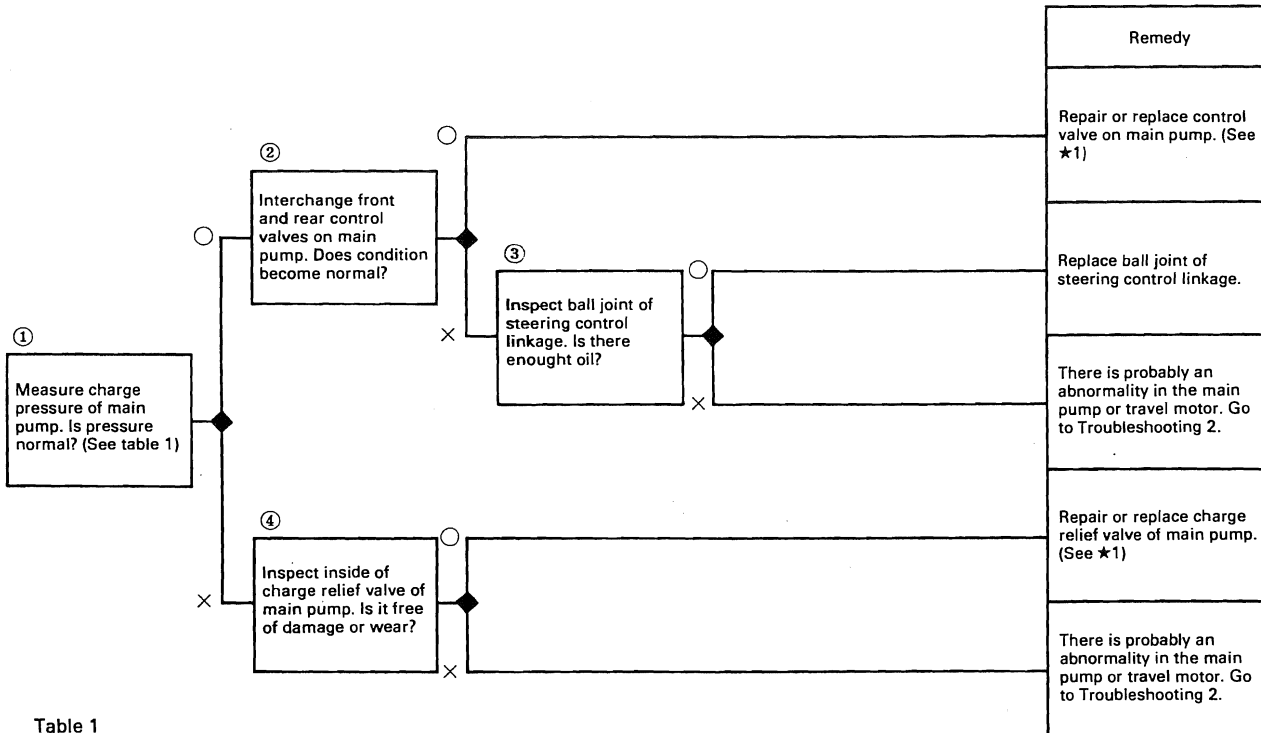

Table 1

Model	Charge pressure of main pump (Engine at 1000 rpm)
MST-500	20 kg/cm <sup>2</sup>
MST-600	Neutral 13 — 14 kg/cm <sup>2</sup>
MST-2000	On load 11 — 13 kg/cm <sup>2</sup>
MST-2200, 2500	25 kg/cm <sup>2</sup>

★1: When checking or replacing any valve, always check that there is no dirt or dust caught in it.

## 15. Hydraulic oil overheats.

Ask the operator the following points.

- Check nature of operation (amount of load), jobsite conditions. Is machine being overloaded?

Checks before troubleshooting

- Is oil level in hydraulic tank correct?
- Is the fan belt tension correct?

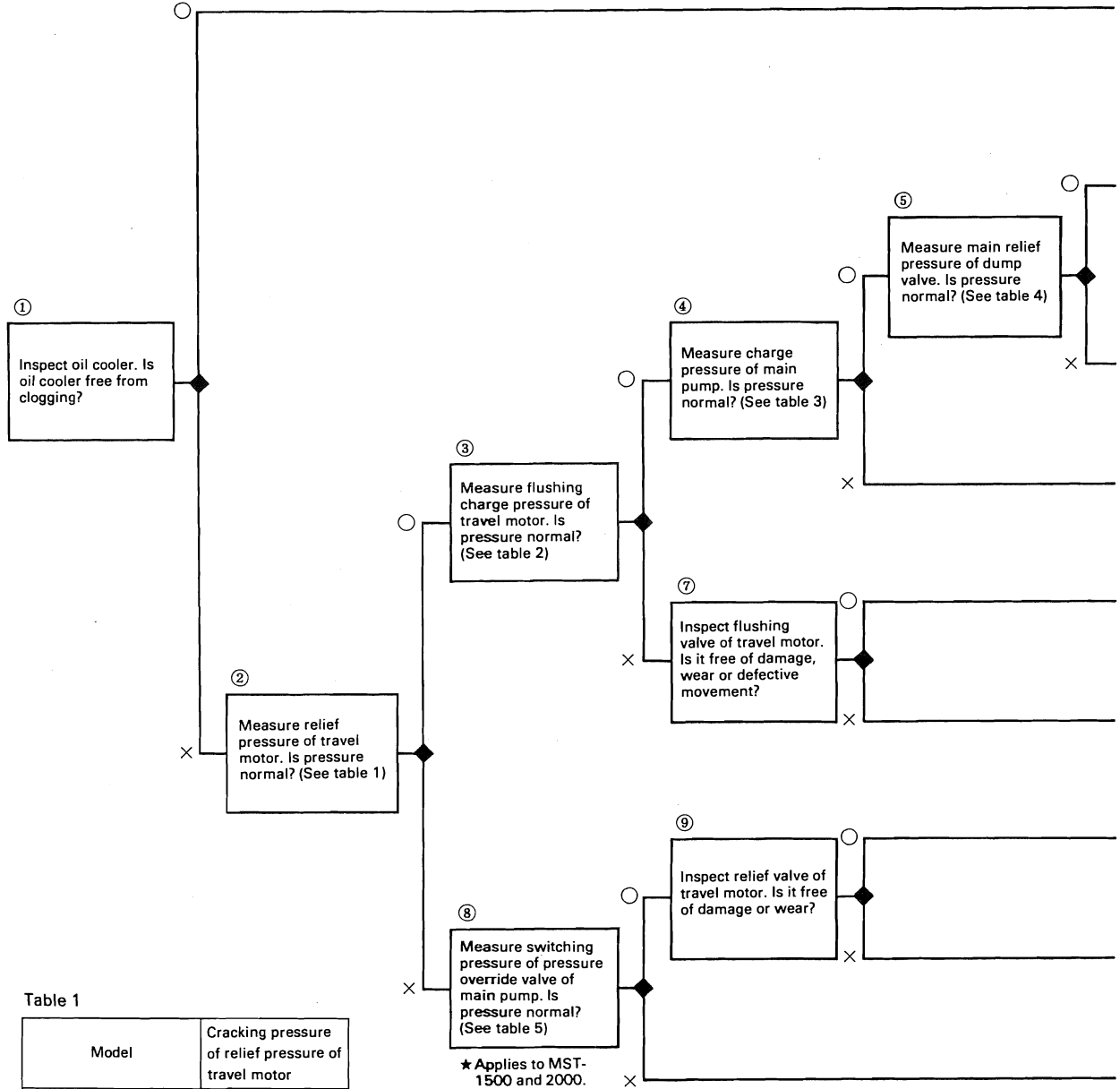

Table 1

Model	Cracking pressure of relief pressure of travel motor
MST-500	280 kg/cm <sup>2</sup>
MST-600	315 kg/cm <sup>2</sup>
MST-700, MST-800	350 kg/cm <sup>2</sup>
MST-1100	385 kg/cm <sup>2</sup>
MST-1500 (#15001—15164)	385 kg/cm <sup>2</sup>
MST-1500 (#15165—)	350 kg/cm <sup>2</sup>
MST-2000 (#K20101—20126, 20128) (#M02101—02104)	385 kg/cm <sup>2</sup>
MST-2000 (#K20127, 20129—) (#M02105—)	350 kg/cm <sup>2</sup>
MST-2200	325 kg/cm <sup>2</sup>
MST-2500	350 kg/cm <sup>2</sup>

Table 2

Model	Cracking pressure of travel motor flushing charge
All models	12—13 kg/cm <sup>2</sup>

Table 3

Model	Charge pressure of main pump <sup>1</sup> (Engine at 1000 rpm)
MST-500	20 kg/cm <sup>2</sup>
MST-600	Neutral 13—14 kg/cm <sup>2</sup>
MST-2000	On load 11—13 kg/cm <sup>2</sup>
MST-2200, 2500	25 kg/cm <sup>2</sup>

		Remedy
		Repair or replace oil cooler.
⑥		Repair or replace check valve inside main pump. (See ★1)
		Inspect main pump or travel motor.
		Repair or replace main relief valve of dump control valve. (See ★1)
		Repair or replace charge relief valve of main pump. (See ★1)
		Repair or replace flushing valve of travel motor. (See ★1)
		Inspect travel motor.
		Repair or replace relief valve of travel motor. (See ★1)
		Inspect travel motor.
		Repair or replace pressure override valve of main pump. (See ★1)

Table 4

Model	Cracking pressure of main relief valve
MST-500—MST-700	175 kg/cm <sup>2</sup>
MST-800—MST-2500	165 kg/cm <sup>2</sup>

Table 5

Model	Cracking pressure of pressure override valve
MST-1500 (#15094—15164)	370 kg/cm <sup>2</sup>
MST-1500 (#15165—)	350 kg/cm <sup>2</sup>
MST-2000 (#K20101—20126, 20128) (#M02101—02104)	370 kg/cm <sup>2</sup>
MST-2000 (#K20127, 20129—) (#M02105—)	350 kg/cm <sup>2</sup>

★1: When checking or replacing any valve, always check that there is no dirt or dust caught in it.



## 16. Parking brake cannot be released.

Ask the operator the following points.

- Did the problem appear suddenly? Yes = Component seized or broken
- Was there any abnormal noise when the problem appeared? (From what area?) Yes = Component broken.

Checks before troubleshooting

- Is oil level in hydraulic tank correct?
- Is there damage or leakage from parking brake piping?
- Is there damage or leakage from piping between dump control valve and main pump?

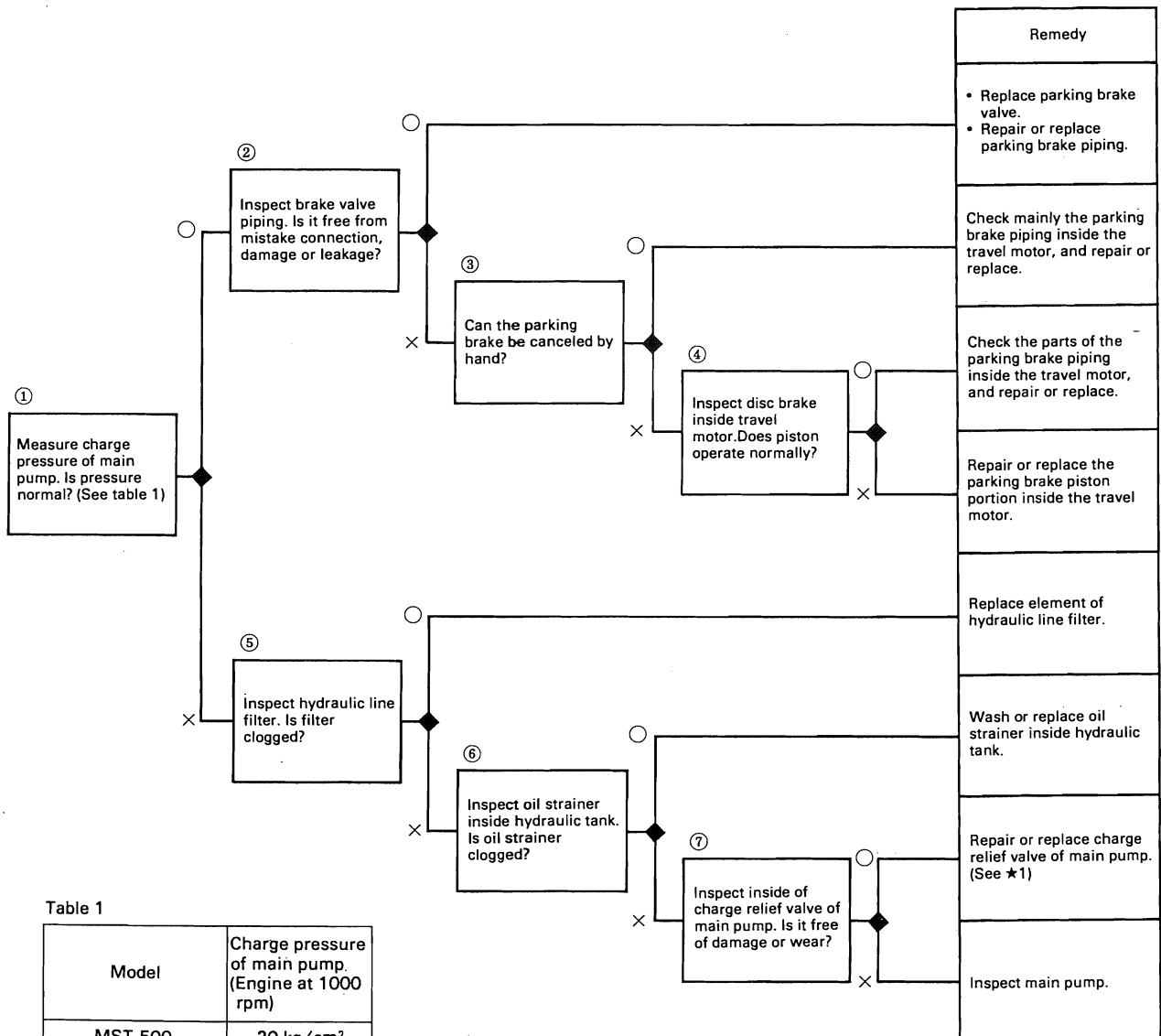

Table 1

Model	Charge pressure of main pump. (Engine at 1000 rpm)
MST-500	20 kg/cm <sup>2</sup>
MST-600.	Neutral 13 — 14 kg/cm <sup>2</sup>
MST-2000	On load 11 — 13 kg/cm <sup>2</sup>
MST-2200, 2500	25 kg/cm <sup>2</sup>

★1: When checking or replacing any valve, always check that there is no dirt or dust caught in it.

## 17. Parking brake does not take effect.

Ask the operator the following points.

- Did the problem appear suddenly? Yes = Component seized or broken
- Was there any abnormal noise when the problem appeared? (From what area?) Yes = Component broken.

Checks before troubleshooting

- Is oil level in hydraulic tank correct?
- Is the parking brake piping incorrectly connected?

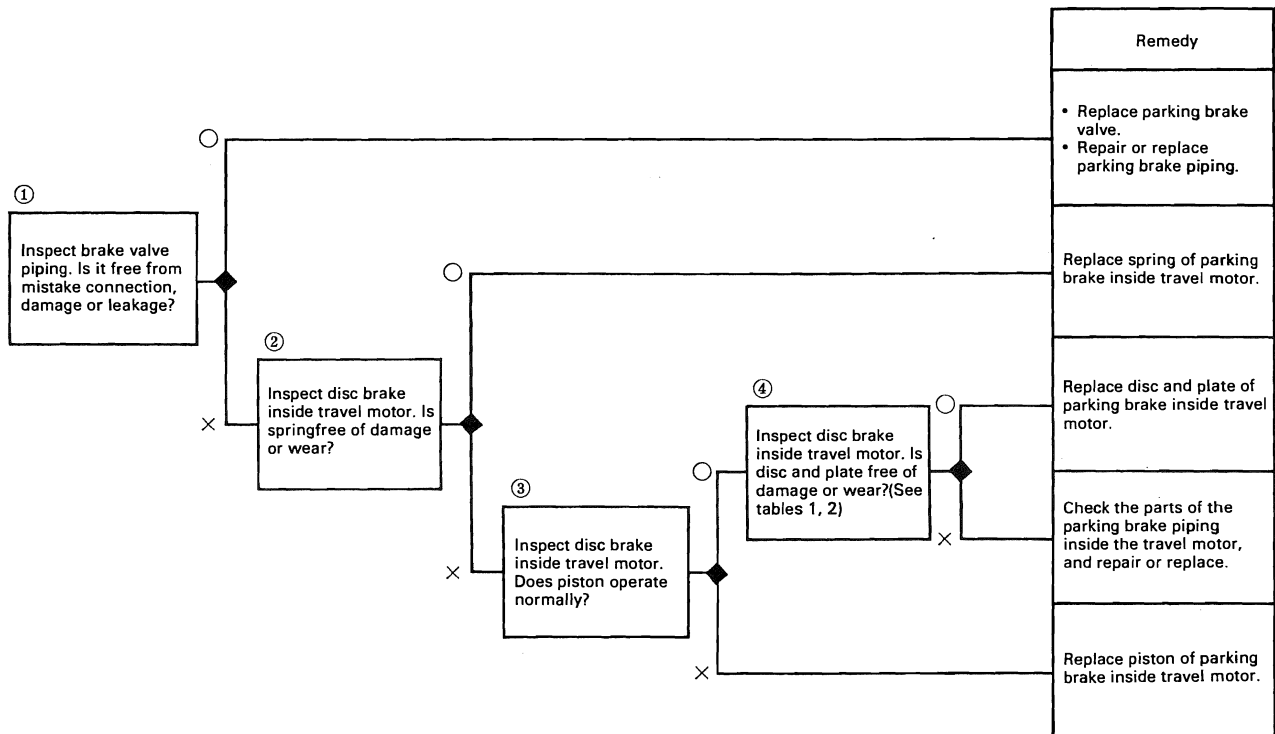

Table 1. ★ Applied to MST-600, 700, 800, 1100, 1500 and 2000

- The thickness of a new brake disc of the MST-600 to 2000 is 1.7 mm, and that of a plate is 1.4 mm.

	Number of discs	Number of plates	Total thickness	Tolerance	Service limit
MST-600	6	7	20.3	-0.5 to 1.0	-1.9
MST-700 - 1500	8	9	26.2	-0.5 to 1.0	-2.3
MST-2000	11	12	35.5	-0.5 to 1.0	-3.0

Table 2. ★ Applied to MST-2200 and 2500.

- For the MST-2200 and 2500, the brake plate is a plate type, so judge it as an individual part.

	Number used	Standard thickness (each)	Repair limit (each)
Disc	8	2.6 mm	2.4 mm
Plate	9	1.2 mm	1.1 mm

- ★ Even if the brake disc and plate are within the standard values given below, replace them if there is uneven wear, damage, or discoloration.

## 18. Abnormal noise generated.

Ask the operator the following points.

- Where does the abnormal noise come from? What kind of noise is it?
- Did the abnormal noise suddenly start? Yes = Component broken or fallen out.
- ★ Carry out the troubleshooting from the area where the operator said he heard abnormal noise.

### A) If the sound was like two parts twisting against each other.

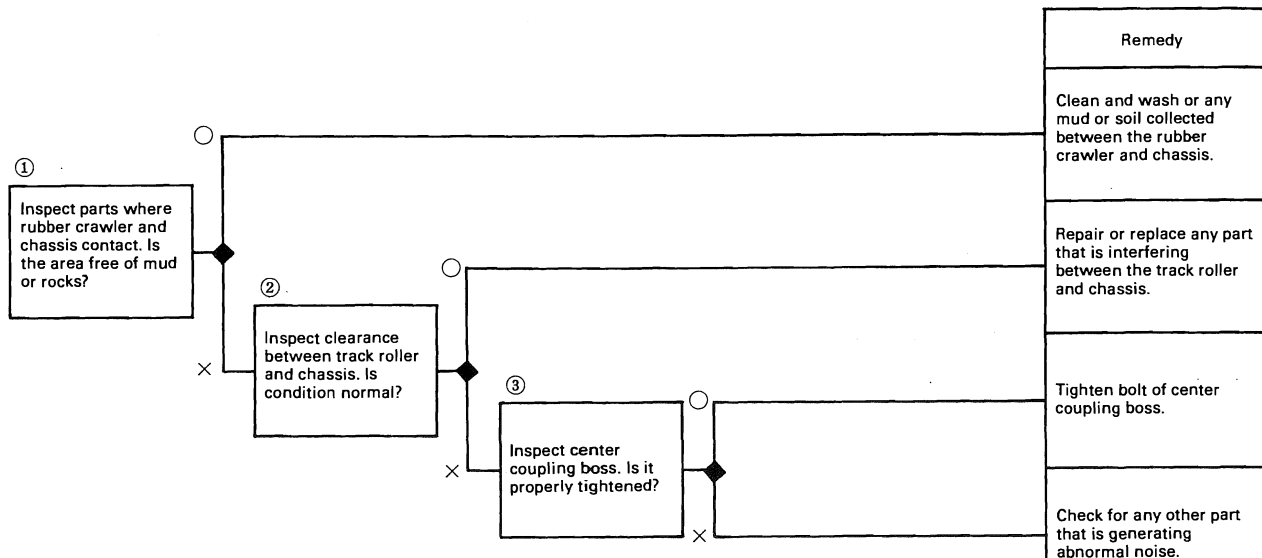

### B) If noise comes from hydraulic equipment system.

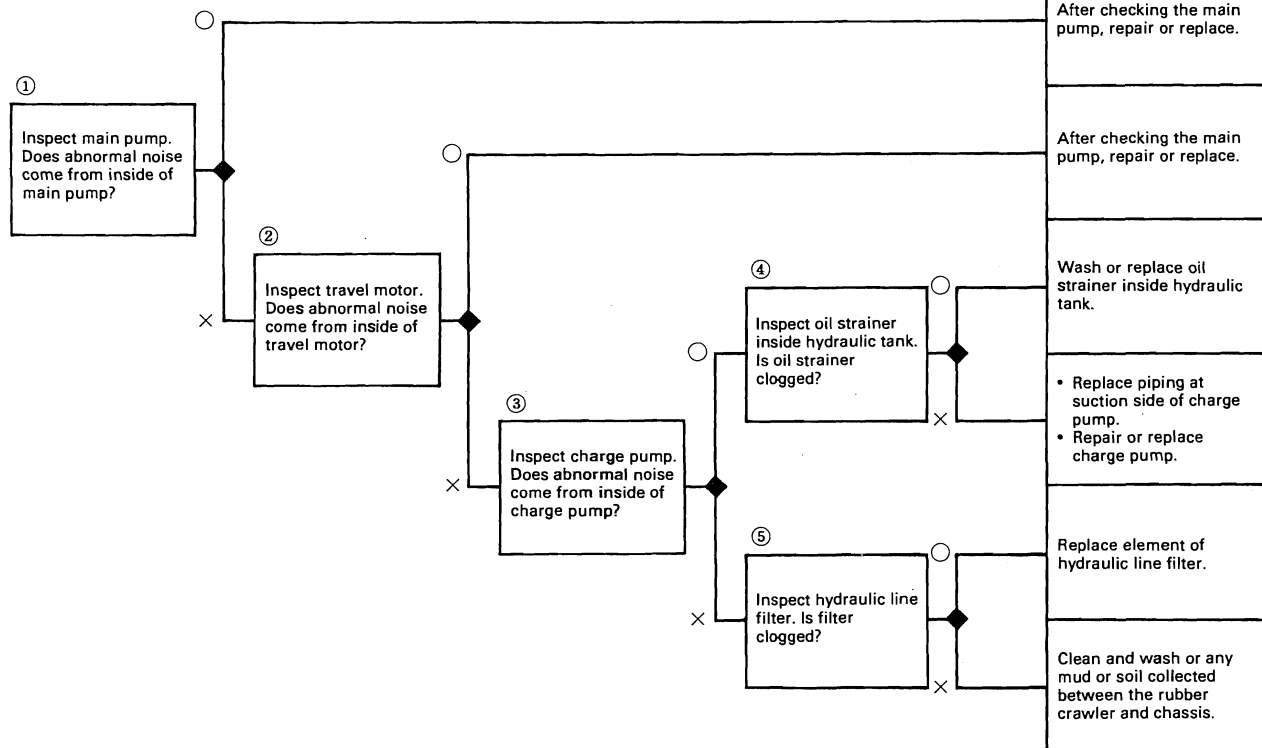

## 19. Hydraulic hose vibrates.

★ The cause is air in the hydraulic oil.

### Checks before troubleshooting

- Is the oil level in the hydraulic tank correct?
- Is there damage or leakage from each piping?

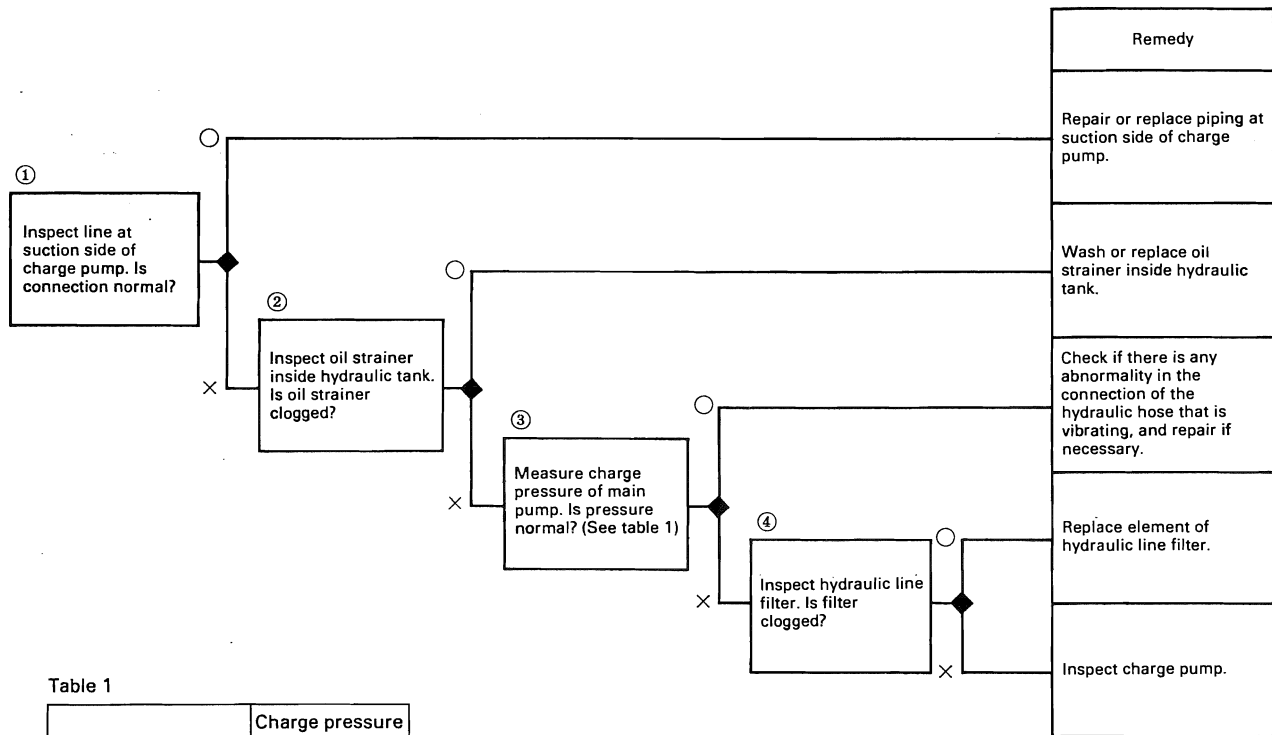

Table 1

Model		Charge pressure of main pump (Engine at 1000 rpm)
MST-500		20 kg/cm <sup>2</sup>
MST-600	Neutral	13 — 14 kg/cm <sup>2</sup>
MST-2000	On load	11 — 13 kg/cm <sup>2</sup>
MST-2200, 2500		25 kg/cm <sup>2</sup>

## 20. Hydraulic charge lamp in operator's compartment lights up.

### Checks before troubleshooting

- Is oil level in hydraulic tank correct?
- Is there damage or leakage from piping between hydraulic tank and charge pump?
- Is there damage or leakage from piping between charge pump – dump control valve – main pump charge port?

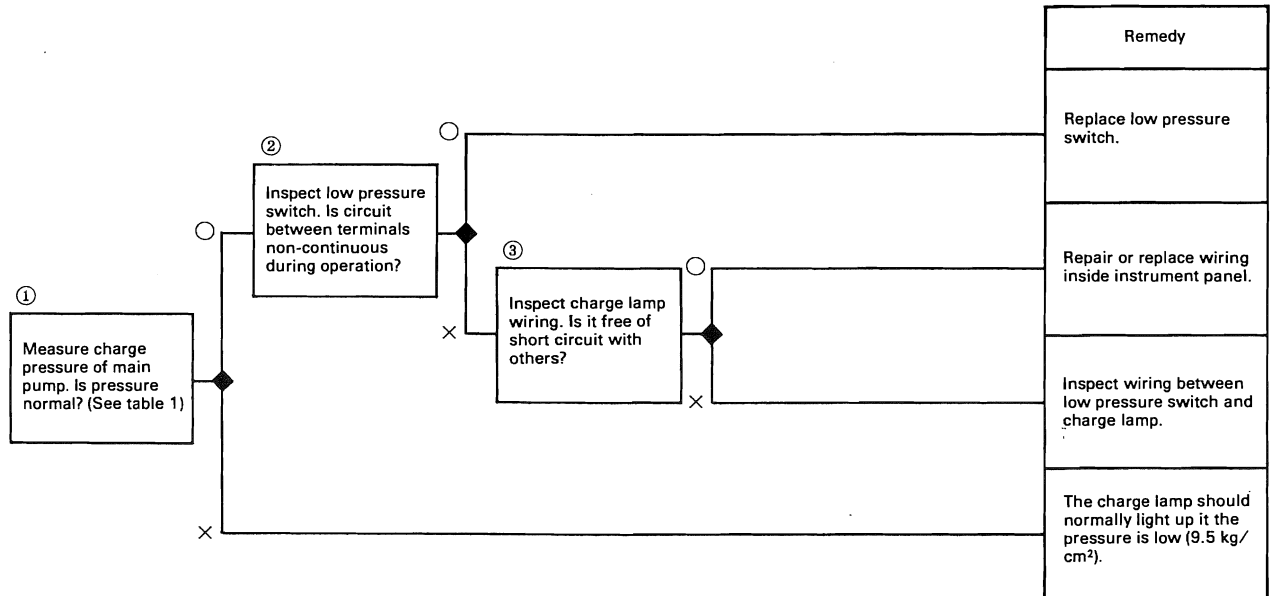

Table 1

Model	Charge pressure of main pump (Engine at 1000 rpm)
MST-500	20 kg/cm <sup>2</sup>
MST-600	Neutral 13 — 14 kg/cm <sup>2</sup>
MST-2000	On load 11 — 13 kg/cm <sup>2</sup>
MST-2200, 2500	25 kg/cm <sup>2</sup>

## 21. Rubber crawler often comes off.

Ask the operator the following points.

- Check nature of operation (amount of load), jobsite conditions. Is the method of operation correct?

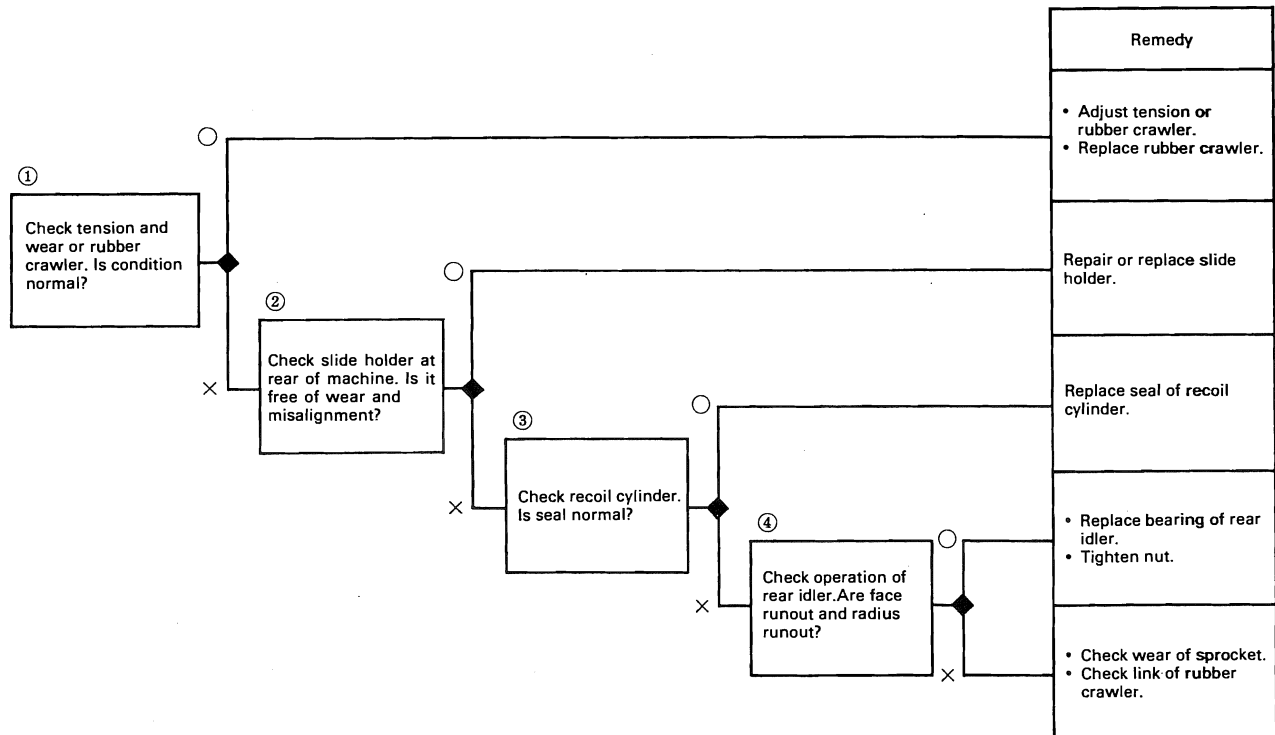

**22. Even when the low/high speed selector switch is set to HIGH, speed does not change.**  
[Applies to MST-2500]

Ask the operator the following points.

- Did the problem suddenly occur? Yes = Seized or damaged equipment
- Was there any abnormal noise when this happened (from which area)? Yes = Broken equipment

Checks before troubleshooting

- Is the oil level in the hydraulic tank correct?
- Is the battery properly charged?
- Is there any damage or oil leakage from the piping between the hydraulic tank and charge pump?
- Is there any damage or oil leakage from the piping between the charge pump – dump control valve – charge relief valve?
- Is there any damage or oil leakage from the piping between the charge relief valve – high/low speed solenoid selector valve – travel motor?
- Is there any damage or oil leakage from the parking brake piping?
- Is the parking brake applied?

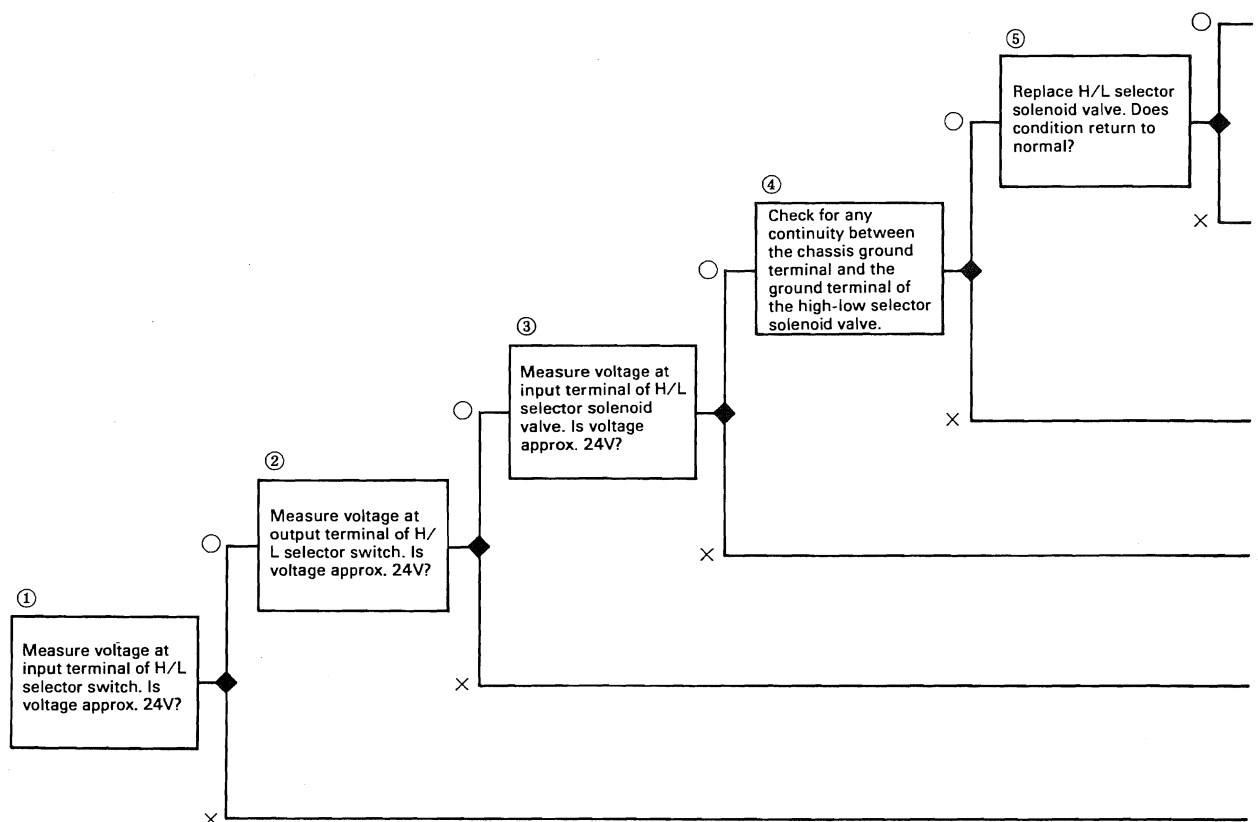

	Remedy
	Replace H/L selector solenoid valve.
<p>⑥</p> <div data-bbox="228 842 415 978"> <p>Inspect piping of H/L selector line. Is connection normal?</p>  </div>	Repair or replace piping of H/L selector line.
	Inspect travel motor.
	Repair or replace wiring of ground line of H/L selector solenoid valve.
	Repair or replace wiring between H/L selector switch and solenoid valve.
	Replace H/L selector switch.
	Repair or replace wiring of power source line of H/L selector switch.



## 23. Battery does not charge.

Ask the operator the following points.

- Did the battery suddenly stop charging? Yes = Alternator broken, disconnection

### Checks before troubleshooting

- Is there any disconnection in fuse (40A) of instrument panel back side?
- Is there any disconnection in wiring between battery, starting switch, alternator, ammeter?
- Is level, specific gravity of electrolyte in battery correct? Is voltage correct (20 – 30V)? Is battery broken?
- Is tension of alternator V-belt insufficient?

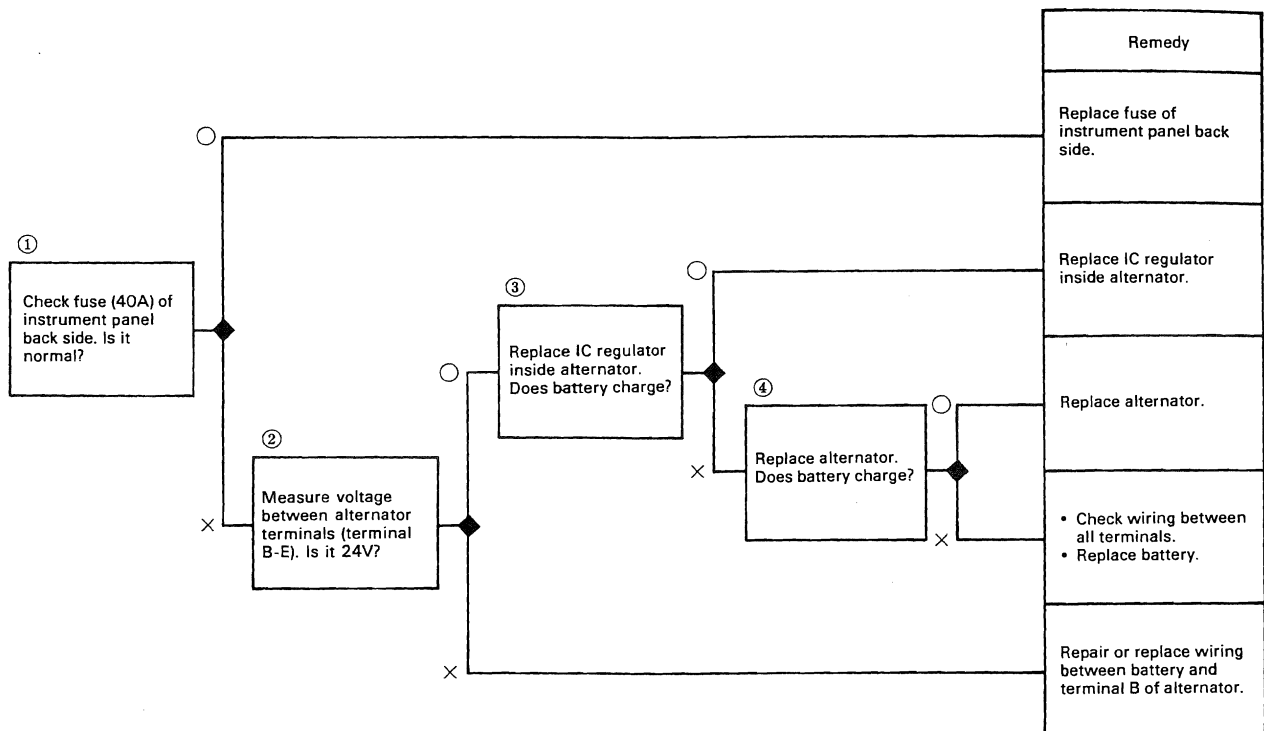

★1: The location of the control panel fuse differs according to the machine serial number.

- Old location: Fuse E at front face of control panel
- New location: Inside wiring harness at rear face of control panel

	Old location serial No.	New location serial No.
MST-500	50101—50132	50133—
MST-600	1601—1994	1995—
MST-700	70101—70278	70279—
MST-800	866—1346	1347—
MST-1100	11101—11271	11272—
MST-1500	15009—15060	15061—
MST-2000	20101—20159	20160—
MST-2500	—	25134—